

KSYRIUM ELITE S

Use: for road bike or cyclo-cross bike use only. Any other use (such as on a tandem or off-road bike...) is highly inadvisable, is the sole responsibility of the user and voids the Mavic warranty.



Recommended maximum weight of the cyclist and equipment: 100 kg.

WHEEL WEIGHT WITHOUT QUICK-RELEASE SKEWER AND WITHOUT CLINCHER

| | |
|-----------|-------|
| Front | 680 g |
| Rear M10 | 855 g |
| Rear ED11 | 840 g |

WHEEL REFERENCES

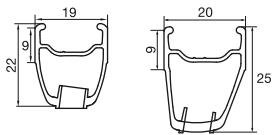
| | |
|-----------|------------|
| Front | 325 732 10 |
| Rear M10 | 325 733 11 |
| Rear ED11 | 325 734 12 |
| Pair M10 | 325 735 14 |
| Pair ED11 | 325 736 14 |

| RIMS | SALES REFERENCES | Front: 330 023 10 Rear: 330 023 13 |
|--|---|---|
|  |  Ø VALVE HOLE Ø: 6.5 mm |  RECOMMENDED TYRE WIDTH Dimensions: 622x15C Recommended clincher width: 23 to 32 mm |
| | When replacing the rear rim: 1. With the valve hole near you, the two raised indicator bumps must be to the right of the valve hole. 2. The spoke in the first hole to the right of the valve hole should be inserted in the drive side. | |

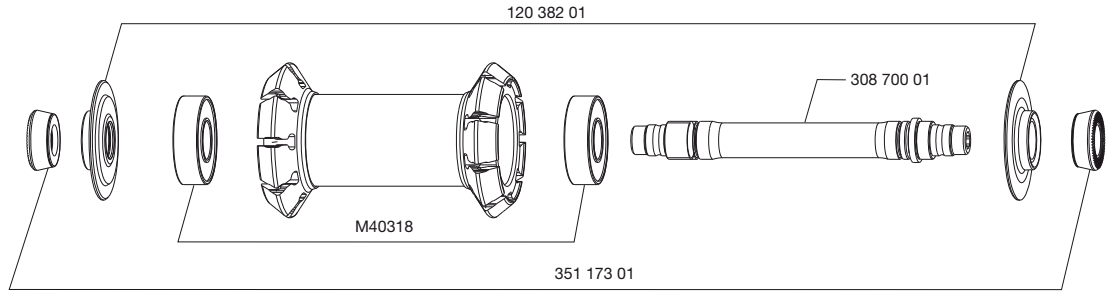
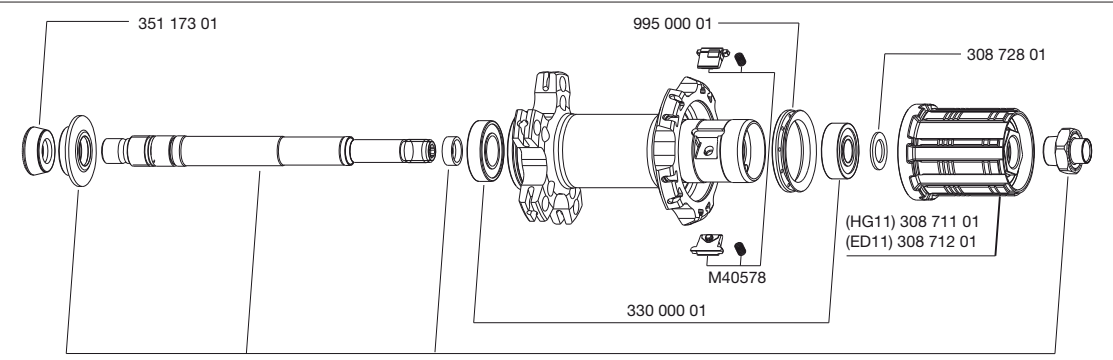
| HUBS | MAINTENANCE: Clean with a dry cloth or soapy water if necessary. Do not use a high-pressure washer. | |
|--|---|--|
|  | | |
|  | | |

| WHEEL BUILDING | REFERENCES AND LENGTHS: | Front: 330 027 01, length 285.5 mm (per 10, integrated nipples) Drive side: 120 306 01, length 275 mm (per 9 + 1 decorated, integrated nipples) Non-drive side: 120 307 01, length 301 mm (per 11, integrated nipples) |
|------------------|---|--|
| FEATURES: | Front: black, swaged, bladed, straight pull steel spokes with integrated and self-locking M7 nipples Rear: black, bladed, straight pull steel spokes with integrated and self-locking M7 nipples | LACING PATTERN: Front: radial Rear: Isopulse |
| | | TENSION: Front: 75 to 85 kg. Rear drive side: 140 to 160 kg |

| ACCESSORIES | WHEELS SUPPLIED WITH: | MAINTENANCE |
|---|-----------------------|--|
| <ul style="list-style-type: none"> BR 301 front quick-release 996 039 01 BR 301 rear quick-release 996 040 01 2 multifunction adjustment wrenches 325 423 01 Yksion Pro White GripLink 23 mm front clincher (328 351 23) Yksion Pro White PowerLink 23 mm rear clincher (328 352 23) Mavic butyl inner tubes (127 385 01) ED11 12D locking ring (with rear wheel ED11) 108 317 01 Wheel and clincher user guide | | Specific tool: <ul style="list-style-type: none"> Front bearing: M40120 Rear bearing: M40120 and 351 266 01 Spoke wrench: 996 079 01 |
| Refer to the website for quick and convenient access to maintenance information (replacement of an axle, bearings, free wheel, spokes, and rims) www.tech-mavic.com | | |