

MAVIC DEEMAX DH YLW 27.5

1
2024
FRONT

ASTM CATEGORY 5 : GRAVITY RIDING FOCUSED ON THE DESCENT

For a longer longevity of the wheel, Mavic recommends that the total weight supported by the wheels doesn't exceed 150kg, bike included

Minimum tyre size: width 52mm - pressure max. 2.95Bar/43PSI

Non-Boost : 12 to 9mm rear adapter for quick release (V2510801)

REFERENCES WHEELS

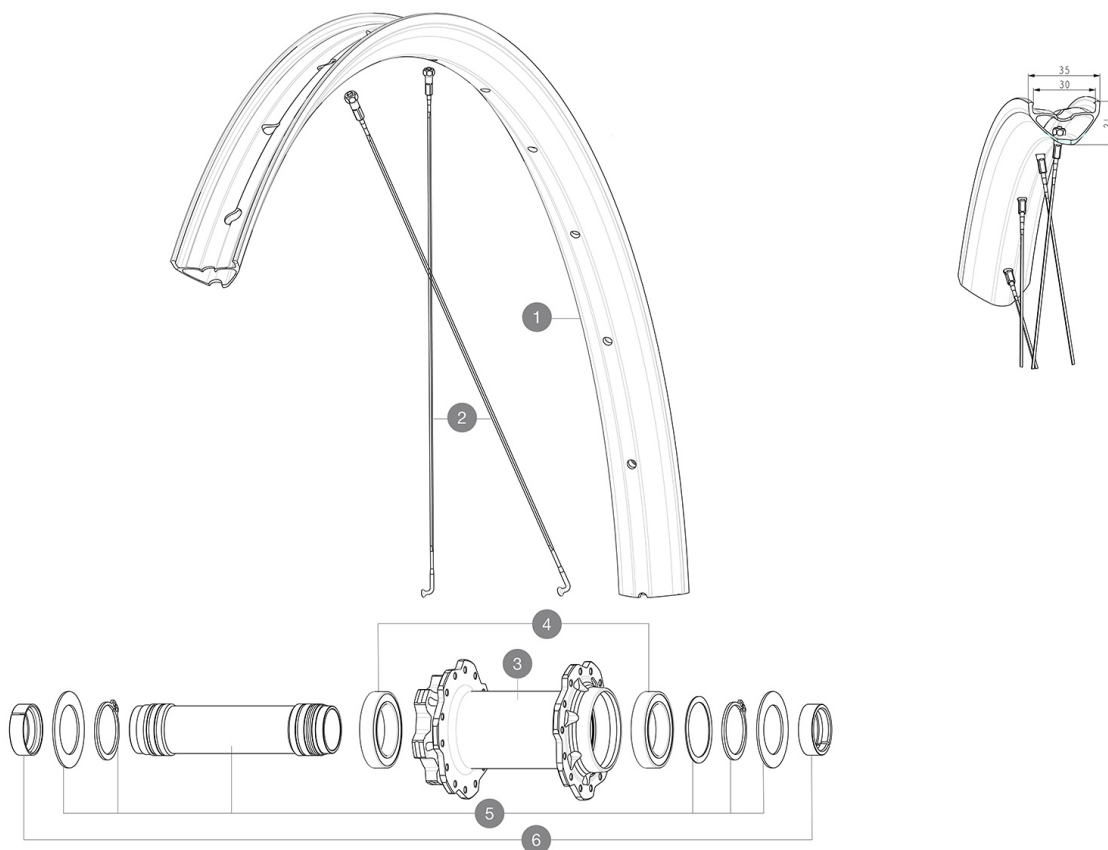

MAVIC DEEMAX DH YLW 27.5

DELIVERED WITH

User guide	
UST valve and accessories (129 838 01)	
Pre-installed tubeless rim tape	
User guide	
Pre-installed tubeless rim tape	
UST valve and accessories (129 838 01)	
Specific disc bolts	
Specific disc bolts	
12 to 9mm rear adapter for quick release (V2510801)	

COMPATIBILITY

Freewheel body: convertible SHIMANO MS (kit V3990101 sold separately)	
Freewheel body: convertible SHIMANO MS (kit V3990101 sold separately)	
Freewheel body: convertible SHIMANO HG MTB aluminium (kit V3780101 sold separately)	
Freewheel body: convertible SHIMANO HG MTB aluminium (kit V3780101 sold separately)	
Freewheel body: convertible SHIMANO HG MTB steel (kit V3790101 sold separately)	
Freewheel body: convertible SHIMANO HG MTB steel (kit V3790101 sold separately)	
ID360 Shimano / Sram freewheel body (V3430101) - Delivered on the wheel	
Rear axle adapters: 12x148 convertible to 9x141 (kit V2510801 sold separately)	
Rear axle adapters: 12x148 convertible to 9x141 (kit V2510801 sold separately)	
ID360 Shimano / Sram freewheel body (V3430101) - Delivered on the wheel	
Instant Drive 360 freewheel technology The new Instant Drive 360 freewheel system is super light and fast to engage with only 9Â°. A large contactless rubber seal provides low friction, while a wide array of end caps makes it super versatile.	

Specifications

RIMS

- **Material** : Mxstal
- **Material** : Mxstal
- **Height** : 22 mm
- **Height** : 22 mm
- **Joint** : SUP welding technology
- **Joint** : SUP welding technology
- **Internal width** : 30 mm
- **Internal width** : 30 mm
- **Drilling** : traditional (front/rear 28 holes)
- **Drilling** : traditional (front/rear 28 holes)

Disc brake specific profile

Disc brake specific profile

Asymmetrical rim design

Asymmetrical rim design

• **ETRTO size 27.5"** : 584x30TC

• **ETRTO size 27.5"** : 584x30TC

• **Tire** : clincher

• **Tire** : clincher

SPOKES

- **Material** : steel
- **Material** : steel
- **Lacing** : front radial, rear crossed 2, contactless
- **Lacing** : front radial, rear crossed 2, contactless

Instant Drive 360 freewheel technology

Isopulse lacing design

Isopulse lacing design

WHEEL HUB

- **Body** : aluminum
- **Body** : aluminum
- **Disc standard** : 6 Bolts only
- **Disc standard** : 6 Bolts only
- **Axle material** : aluminum
- **Axle material** : aluminum
- **Axle size** : rear 12x148 or 12x157
- **Axle size** : rear 12x148 or 12x157
- **Axles** : Front 15X110 (Boost) or 15x100 ; Rear 12X148 (Boost) or 12x142
- **Axles** : Front 15X110 (Boost) or 15x100 ; Rear 12X148 (Boost) or 12x142
- **Front** : Quick release, 12x100 and 15x100 through axle compatible
- **Front** : Quick release, 12x100 and 15x100 through axle compatible
- **Freewheel** : FTS-L steel
- **Freewheel** : FTS-L steel

WHEEL WEIGHTS