

参照ホイール

ASTM E1000 3 : 52mm-
2.35Bar/34PSI
125mm-
1.25Bar/18PSI

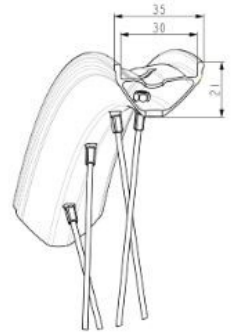

Specifications	Maxi target
Frontal run out	0,5mm
Lateral run out	0,5mm
Centring	1,0mm (2x0,5)
Tension daN	106 > 137
Disc side	

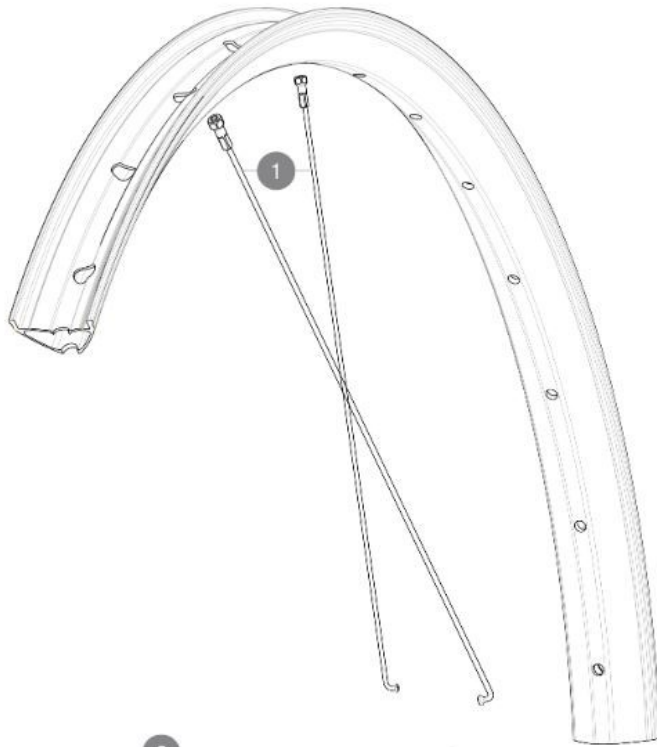
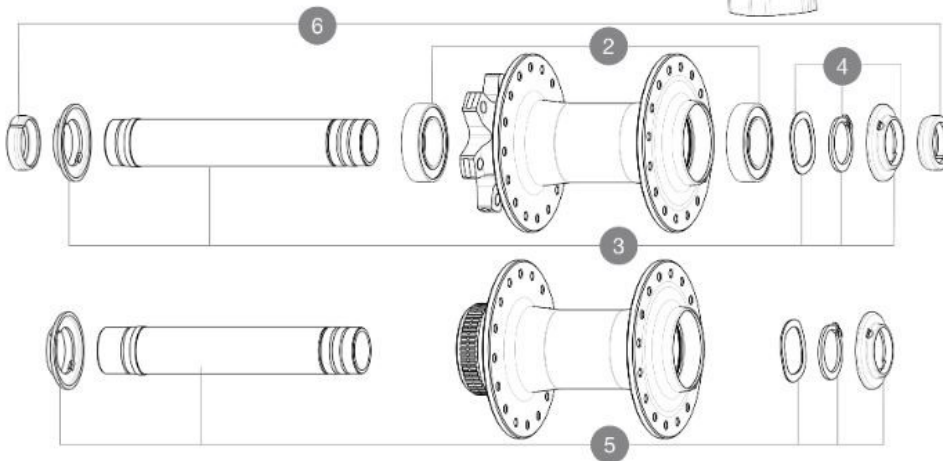

SPOKES

1	V00062431	Kit 16 ft/rr Jbent bk rd spk 293 29"+np
---	-----------	---

OPTIONS

V2374401	TORQUE CAPS 15°31 Adapter MTB QRM Auto > 2019 Frt HUB
----------	---

HUB SHELLS

2	V2500901	KIT BEARINGS 18x30x7 + WAVED WASHER + CLIP
3	V2372401	KIT 110mm AXLE QRM AUTO MTB > 2019
4	V2373001	KIT ADJUST. SYSTEM QRM AUTO ID360 for 17x30x7 bearing
5	V2375601	Kit 110mm axle QRM auto MTB from 2019 DCL

ADAPTERS

5	V2372501	15mm MTB Axle Cap QRM Auto From 2019
	99694101	2 REDUCERS 15/9mm

