

MAVIC ALLROAD S DISC

ASTM CATEGORY 2 : road and offroad with jumps less than 15cm

For a longer longevity of the wheel, Mavic recommends that the total weight supported by the wheels doesn't exceed 120kg, bike included

Recommended tyre sizes: 28 to 64 mm (1.1" to 2.5")

Max. Pressure: see indication on wheel and tyre. If they differ, use the lowest of the 2

Maximum tyre pressure: 4.6bar/67PSI with a 28mm tyre - 32.7bar/39PSI with a 64mm tyre

RUEDAS REFERENCIAS

F90221 ALLROAD S CL 700 12X100

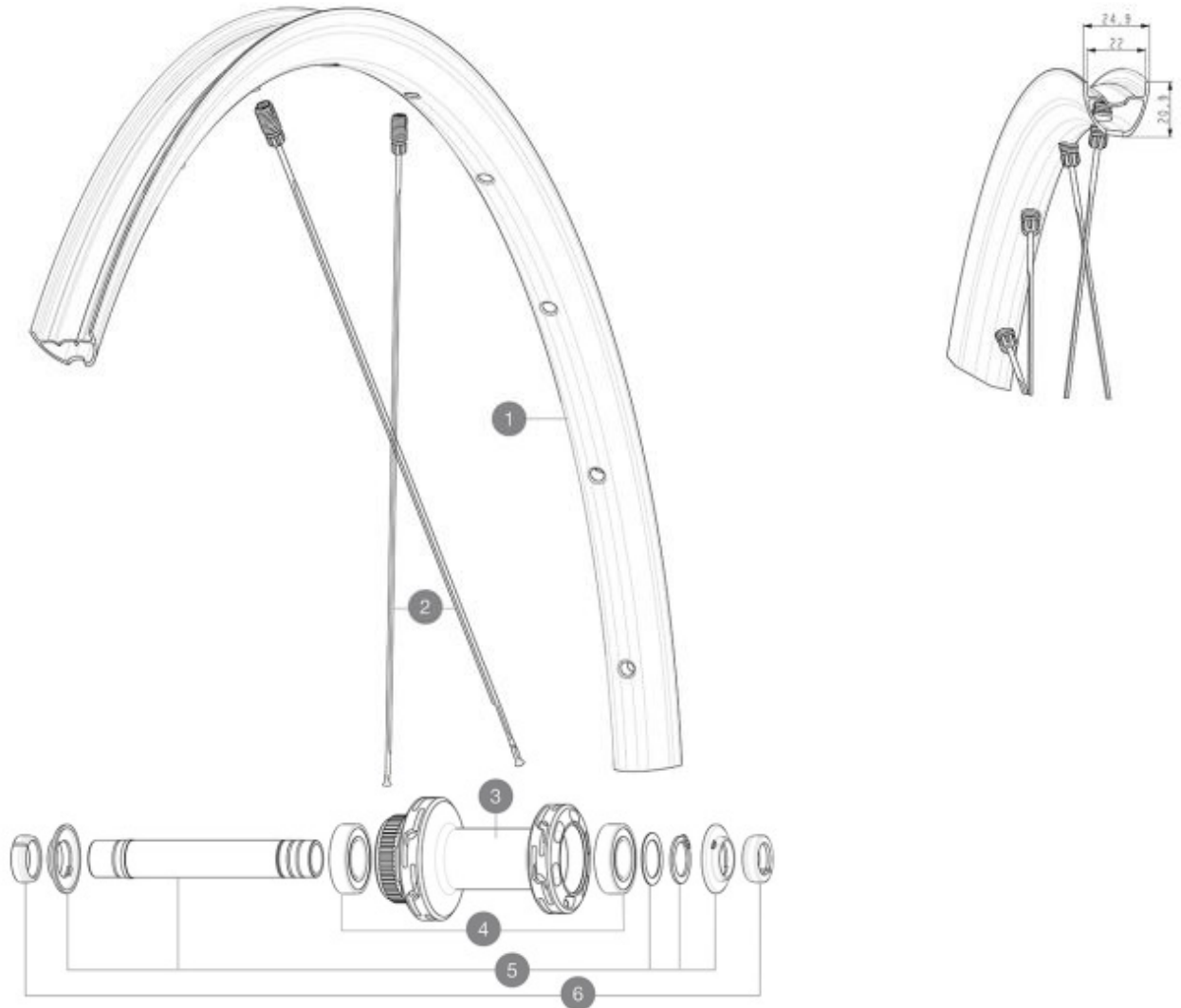
**RIMS**

&NBSP;:

- | | | |
|---|-----------|--|
| 1 | V00097531 | Kit Front/Rear rim Allroad S 23 |
| 1 | V4092115 | Kit Front/Rear rim Allroad S while stock lasts |

SPOKES

- | | | |
|---|----------|---|
| 2 | V4162601 | Kit 12 Front/Rear Allroad S flat spoke 298 M7/7 |
|---|----------|---|

HUB SHELLS

- | | | |
|---|----------|---|
| 3 | N/A | CUERPO DE BUJE |
| 4 | V2500901 | KIT BEARINGS 18x30x7 + WAVED WASHER + CLIP |
| 5 | V2374001 | KIT 12x100mm FRONT AXLE DCL QRM AUTO ALLROAD > 2019 |

OPTIONS

- | | | |
|---|----------|--|
| 6 | V2372501 | 15mm MTB Axle Cap QRM Auto From 2019 |
| | V2680301 | "Kit Ft Road Adapter 12 >> 9mm" |
| | V2373501 | QRM Auto front axle 15mm for DCL Allroad wheels > 2019 |

ENTREGADO CON

UST valve and accessories (129 838 01)	
UST valve and accessories (129 838 01)	
UST valve and accessories (129 838 01)	
Llave de ajuste multifunción (325 423 01)	
User guide	
User guide	
User guide	

COMPATIBILITY

Freewheel: Shimano/Sram, convertible to Campagnolo and XD-R with optional driver bodies	
Freewheel: Shimano/Sram, convertible to Campagnolo and XD-R with optional driver bodies	
Freewheel: Shimano/Sram, convertible to Campagnolo and XD-R with optional driver bodies	
Eje delantero: eje pasante de 12Å mm, fÅcilmente convertible a cierre rÅpido con los adaptadores opcionales. Convertible a 15Å mm mediante sustituci	
Eje delantero: eje pasante de 12x100, fÅcilmente convertible a cierre rÅpido con los adaptadores incluidos. No es compatible con ejes pasantes de 15	
Eje delantero: eje pasante de 12x100, fÅcilmente convertible a cierre rÅpido con los adaptadores incluidos. No es compatible con ejes pasantes de 15	
Rear axle: 12mm thru axle, convertible to Quick Release with optional adapters	
Rear axle: 12mm thru axle, convertible to Quick Release with optional adapters	
Rear axle: 12mm thru axle, convertible to Quick Release with optional adapters	

Specifications

LLANTAS

- **Material** : Mxstal
 - **Height** : 22 mm
- Disc brake specific profile
- **Material** : Mxstal
 - **Material** : Mxstal
 - **Tire** : UST Tubeless and tubetype
 - **Height** : 22 mm
 - **Internal width** : 22 mm
 - **Height** : 22 mm
 - **ETRTO size** : 622x22TSS ROAD
- Hookless profile
- Disc brake specific profile
- Disc brake specific profile
- **Tire** : UST Tubeless and tubetype
 - **Tire** : UST Tubeless and tubetype
 - **Internal width** : 22 mm
 - **Internal width** : 22 mm
 - **ETRTO size** : 622x22TSS ROAD
 - **ETRTO size** : 622x22TSS ROAD
- Hookless profile
- Hookless profile
- Fore
- Fore
- Fore
- UST
- UST
- UST
- SUP
- SUP
- SUP

RADIOS

- **Material** : steel
- **Material** : steel
- **Material** : steel

BUJE DE LA RUEDA

- **Front and rear bodies** : aluminum
 - **Front and rear bodies** : aluminum
 - **Front and rear bodies** : aluminum
 - **Axle material** : aluminum
 - **Axle material** : aluminum
 - **Axle material** : aluminum
- Infinity Hub
- **Front** : Quick release, 12x100 and 15x100 through axle compatible
 - **Front** : Quick release, 12x100 and 15x100 through axle compatible
 - **Front** : Quick release, 12x100 and 15x100 through axle compatible
 - **Rear** : Quick Release, 12x142 and 12x135 compatible
 - **Rear** : Quick Release, 12x142 and 12x135 compatible
 - **Rear** : Quick Release, 12x142 and 12x135 compatible
- Infinity Hub
- Infinity Hub
- El buje estÅ disponible solo para rotores de freno
- Center Lock
- Instant Drive 360
- Instant Drive 360
- Instant Drive 360
- QRM Auto
- QRM Auto
- QRM Auto

VERSIONS

- **Disc standard** : Center Lock (R) only
- **Disc standard** : Center Lock (R) only
- **Disc standard** : Center Lock (R) only
- **Freewheel** : Shimano/Sram or XD-Road

PESOS DE RUEDAS

830