

ASTM CATEGORY 5 : GRAVITY RIDING FOCUSED ON THE DESCENT

For a longer longevity of the wheel, Mavic recommends that the total weight supported by the wheels doesn't exceed 150kg, bike included

Maximum tyre pressure: 3.2bar/46PSI with a 47mm tyre - 2.85bar/41PSI with a 64mm tyre

Recommended tyre sizes: 60mm to 76mm (2.35" to 3.0")

## REFERENCES WHEELS

F92221 Deemax 27,5 21 Ft

F92231 DEEMAX INT 27,5 BST

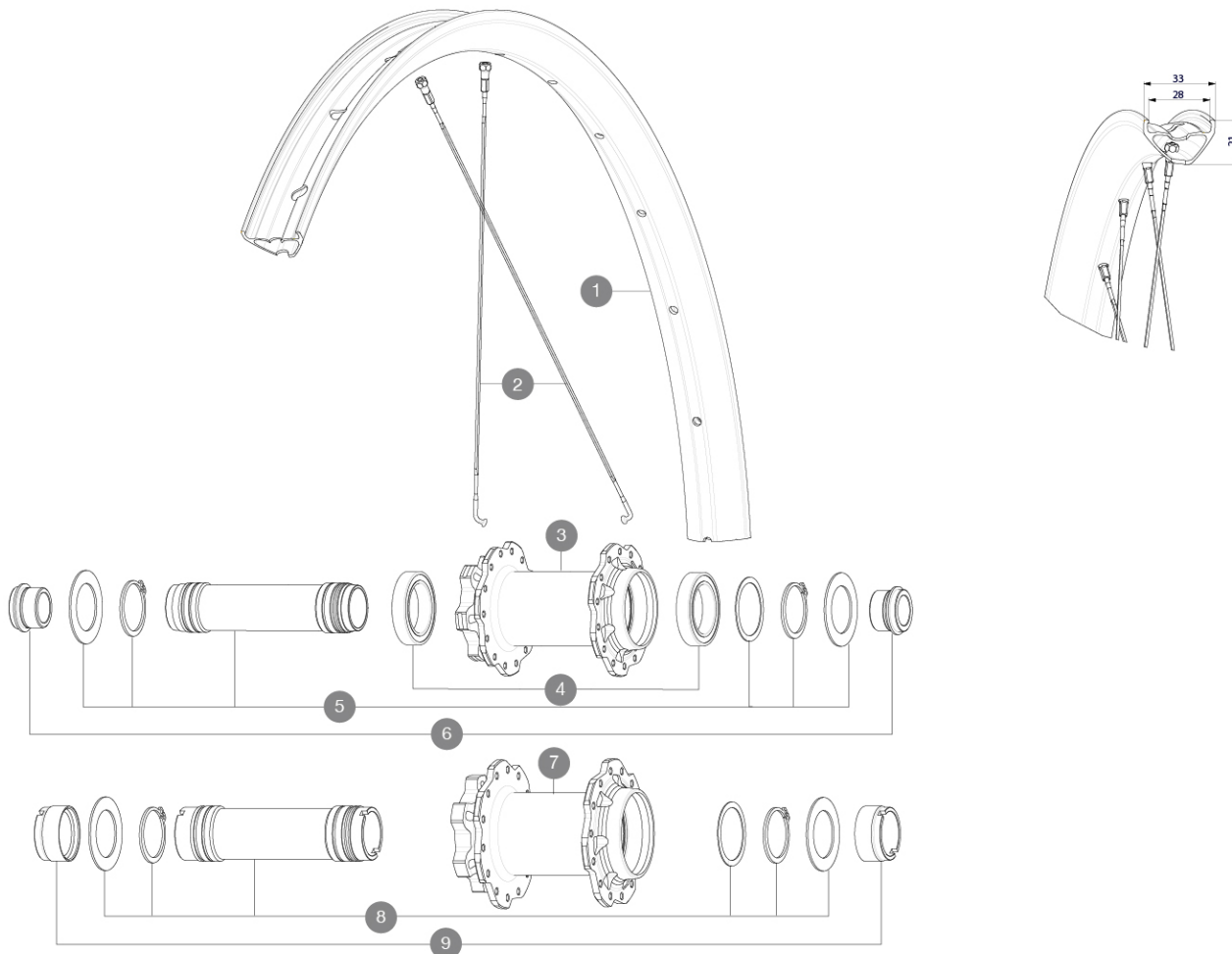

## RIMS



&NBSP::

1	V2640101	UST RIM TAPE 32mm for 28 to 29mm wide rims
	V3766315	Kit Front/Rear rim Deemax 21 27,5"

## SPOKES

2	V2388001	KIT 14 J BENT STEEL SPOKES 281mm DEEMAX DH 27,5" + black st
---	----------	---

## HUB SHELLS

3	N/A	HUB BODY
4	M40179	FRONT BEARING 25x37x7 20mm AXLE
5	V2373701	KIT 20x110mm BOOST AXLE QRM AUTO MTB > 2019
7	N/A	HUB BODY
8	V2373801	KIT 20x110mm AXLE QRM AUTO MTB > 2019

## ADAPTERS

6	12982801	ADAPTER Ft 20 to 15mm
9	12982901	ADAPTER Ft 20x110mm

# MAVIC DEEMAX 27,5

## DELIVERED WITH

UST valve and accessories (129 838 01)	
UST valve and accessories (129 838 01)	
Pre-installed tubeless rim tape	
Pre-installed tubeless rim tape	
Multifunction adjustment wrench (delivered with rear wheel) (325 423 01)	
Multifunction adjustment wrench (delivered with rear wheel) (325 423 01)	
2 replacement spokes with each wheel	
2 replacement spokes with each wheel	
20X110mm boost adapters delivered with front Boost wheel	
20X110mm NON-boost adapters delivered with NON boost front wheel	
12X150 adapters delivered with 12X157 rear wheel	
20X110mm boost adapters delivered with front Boost wheel	
20X110mm NON-boost adapters delivered with NON boost front wheel	
12X150 adapters delivered with 12X157 rear wheel	

## COMPATIBILITY

Front axle: 15x110 Boost, convertible to 20x110 Boost thru axle with adapters	
Front axle: 15x110 Boost, convertible to 20x110 Boost thru axle with adapters	
Boost Axles : 15X110 ; 12X148	
Boost Axles : 15X110 ; 12X148	
DH spacing axles: 12X150 , 12x157 , 12X157-7speed	
DH spacing axles: 12X150 , 12x157 , 12X157-7speed	
Freewheel: Shimano HG9, XD or Micro Spline	
Freewheel: Shimano HG9, XD or Micro Spline	

## Specifications

### RIMS

- **Material** : Mxstal
  - **Material** : Mxstal
  - **Material** : S6000 Aluminum
  - **Material** : S6000 Aluminum
- SUP
- **Drilling** : traditional
  - **Drilling** : traditional
  - **Internal width** : 28 mm
  - **Internal width** : 28 mm
  - **ETRTO size 27.5"** : 584x28TC
  - **ETRTO size 27.5"** : 584x28TC
  - **ETRTO size 29"** : 622x28TC
- Black Shield treatment (protects your rim against impacts and scratches)
- Black Shield treatment (protects your rim against

### WHEEL HUB

- Instant Drive 360  
QRM Auto
- **DH spacing axles** : 12X150 , 12x157 , 12X157-7speed available
- Hub available with 6-bolt brake rotors
- **Axles** : Front 15X110 Boost ; Rear 12X148 Boost
- **DH spacing axles** : 12X150 , 12x157 , 12X157-7speed available
- Hub available with 6-bolt brake rotors
- **Axles** : Front 15X110 Boost ; Rear 12X148 Boost
- 24 teeth ratchet  
Instant Drive 360  
QRM Auto

### VERSIONS

### WHEEL WEIGHTS

955