

MAVIC **DEEMAX PARK 27.5****REFERENCES WHEELS**

ASTM CATEGORY 5 : GRAVITY RIDING FOCUSED ON THE DESCENT

For a longer longevity of the wheel, Mavic recommends that the total weight supported by the wheels doesn't exceed 150kg, bike included

Minimum tyre size: width 52mm - pressure max. 2.95Bar/43PSI

Non-Boost : 12 to 9mm rear adapter for quick release (V2510801)

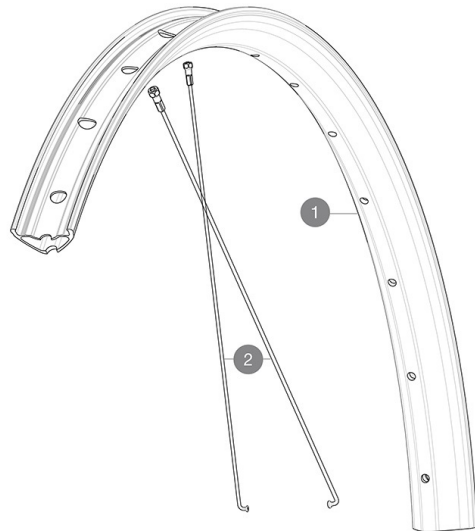

Specifications	Maxi target
Frontal run out	0,4mm
Lateral run out	0,5mm
Centring	1,0mm (2x0,5)
Tension daN FWB side	99 > 121

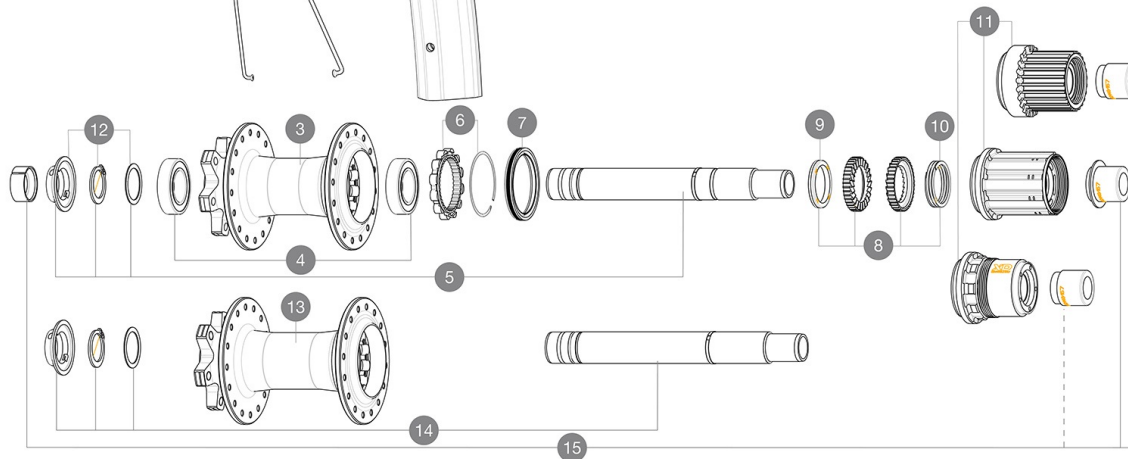
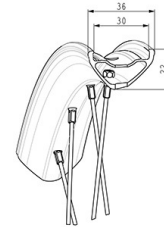
**RIMS**

&NBSP;:

1	V00096631	Kit Front/Rear rim Deemax Park 27,5"
	V3750101	35mm UST Green Tape for 30mm wide rims

SPOKES

2	V00062531	Kit 16ft/rr Jbent bk rd spk275 27,5"+np
----------	-----------	-----------------------------------------

HUB SHELLS

4	M40076	HUB BEARINGS 17x30x7 6903 x 2
5	V2372201	KIT ID360 148 D6T AXLE WITH CLIP
6	V2252701	KIT ID360 INSERT SHAPED EAR LOBE > 2017
7	V2251601	KIT ID360 SEAL + GREASE while stock lasts
8	V2375201	KIT ID360 24 TEETH 2 RATCHET + MTB SPRING + PAD (specific)
9	V2375401	KIT ID360 MTB 24T 3 NOISE REDUCING PADS
10	V2372901	KIT 3 ID360 MTB SPRINGS
11	V3780101	HG9 Alloy MTB Freewheel Body ID360
11	V3990101	MicroSpline MTB Freewheel Body ID360
11	V3740101	XD MTB Freewheel Body ID360
12	V2373001	KIT ADJUST. SYSTEM QRM AUTO ID360 for 17x30x7 bearing
14	V2374801	Kit ID360 150/157 D6T AXLE WITH CIRCLIP

OPTIONS

8	V2372801	KIT ID360 2x40 TEETH RATCHETS + MTB SPRING + GREASE + PAD
----------	----------	-----------------------------------------------------------

ADAPTERS

15	V2510701	ID360V2RrAxleAdapt12x142/148
-----------	----------	------------------------------

DELIVERED WITH

User guide	
User guide	
User guide	
UST valve and accessories (129 838 01)	
Pre-installed tubeless rim tape	
User guide	
Pre-installed tubeless rim tape	
Pre-installed tubeless rim tape	
Pre-installed tubeless rim tape	
UST valve and accessories (129 838 01)	
UST valve and accessories (129 838 01)	
UST valve and accessories (129 838 01)	
2 replacement spokes with each wheel	
2 replacement spokes with each wheel	
2 replacement spokes with each wheel	
12 to 9mm rear adapter for quick release (V2510801)	
12 to 9mm rear adapter for quick release (V2510801)	
12 to 9mm rear adapter for quick release (V2510801)	

COMPATIBILITY

Freewheel body: convertible SHIMANO MS (kit V3990101 sold separately)	
Freewheel body: convertible SHIMANO MS (kit V3990101 sold separately)	
Freewheel body: convertible SHIMANO MS (kit V3990101 sold separately)	
Freewheel body: convertible SHIMANO MS (kit V3990101 sold separately)	
Freewheel body: convertible SHIMANO HG MTB steel (kit V3790101 sold separately)	
Freewheel body: convertible SHIMANO HG MTB steel (kit V3790101 sold separately)	
Freewheel body: convertible SHIMANO HG MTB steel (kit V3790101 sold separately)	
Freewheel body: convertible SHIMANO HG MTB steel (kit V3790101 sold separately)	
ID360 Shimano / Sram freewheel body (V3430101) - Delivered on the wheel	
ID360 Shimano / Sram freewheel body (V3430101) - Delivered on the wheel	
ID360 Shimano / Sram freewheel body (V3430101) - Delivered on the wheel	
Rear axle adapters: 12x148 convertible to 9x141 (kit V2510801 sold separately)	
Rear axle adapters: 12x148 convertible to 9x141 (kit V2510801 sold separately)	
Rear axle adapters: 12x148 convertible to 9x141 (kit V2510801 sold separately)	
Rear axle adapters: 12x148 convertible to 9x141 (kit V2510801 sold separately)	
QRM Auto bearing preload technology Qualité de Roulements Mavic Auto Our latest innovation. Those cartridge bearings are of course double sealed with C3 internal clearance. Their preload is automatically adjusted to guarantee a perfect spin with no play on the long run.	
QRM Auto bearing preload technology Qualité de Roulements Mavic Auto Our latest innovation. Those cartridge bearings are of course double sealed with C3 internal clearance. Their preload is automatically adjusted to guarantee a perfect spin with no play on the long	