

ASTM CATEGORY 1 : road only  
 Maximum tyre pressure: 4.6bar/67PSI with a 28mm tyre - 32.7bar/39PSI with a 64mm tyre  
 Recommended weight limit : 120kg  
 Maximum tyre pressure: 8.4bar/121PSI with a 23mm tyre - 7.85bar/114PSI with a 32mm tyre  
 Recommended tyre sizes: 21 to 28 mm  
 Max. Pressure: see indication on wheel and tyre. If they differ, use the lower of the 2  
 Max. Pressure: 23mm 8.7 bars - 125 psi  
 Maximum tyre size: width 32mm - pressure max. 8Bar/115PSI  
 Minimum cog width : 7.5mm  
 Minimum cog width : 7.5mm

## REFERENCES WHEELS

F32501 ELLIPSE RB 700

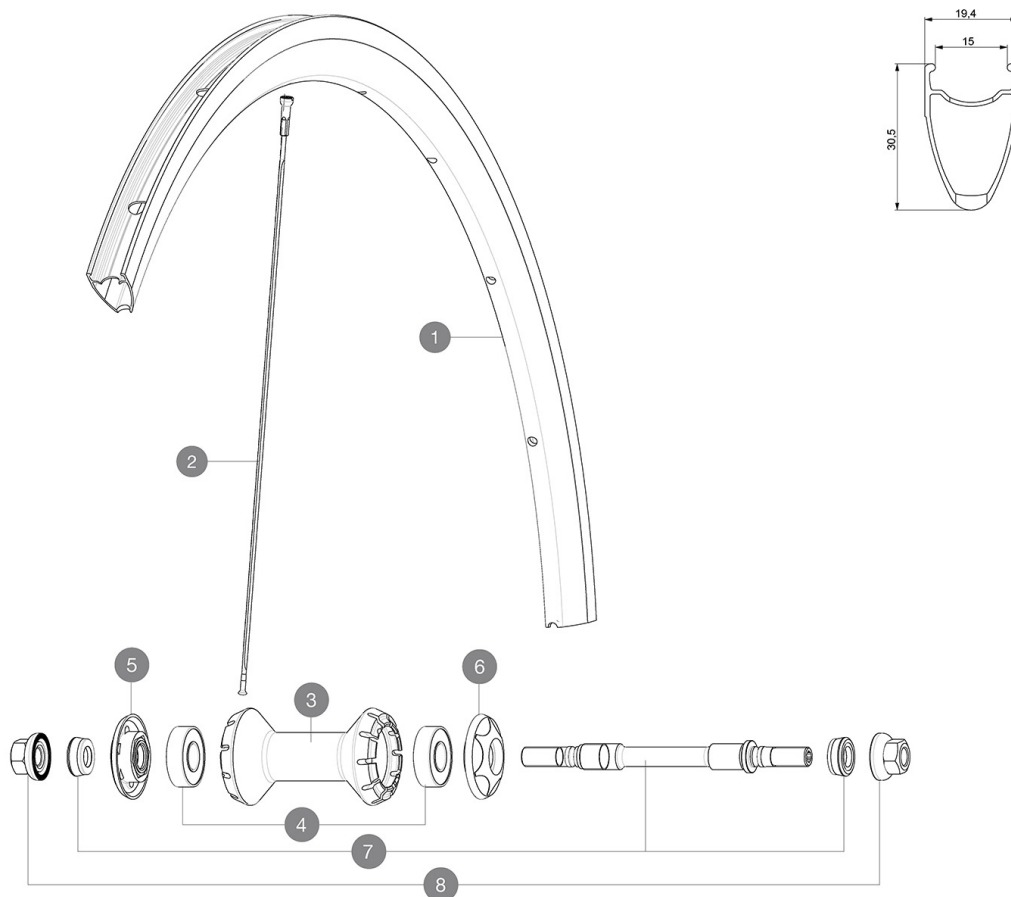

## RIMS



&NBSP;:

1	12033415	KIT FRONT/REAR ELLIPSE 11 RIM
	V2690201	KIT CARBON RIM TAPE 18x622mm - FOR CARBON RIM

## SPOKES

2	12033701	KIT 10 FRONT ELLIPSE 11 BLACK SPOKE 279mm
---	----------	---

## HUB SHELLS

3	N/A	HUB BODY
4	M40318	KIT 2 HUB BEARINGS 6001
5	M40242	AXLE CAP + ADJUSTING NUT
6	M40243	AXLE CAP
7	32386101	ELLIPSE FRONT AXLE + FORK SUPPORTS
8	32388601	2 AXLE BOLTS RR COMETE TRACK/ELLIPSE FT-RR M9

**DELIVERED WITH**

Fixing nuts	
User guide	
Rim tape	
Valve extender	
Tyre sealant syringe	
Fixing nuts	
Cog lock nut	
Fixing nuts	
Fixing nuts	
Fixing nuts	
Fixing nuts	
Fixing nuts	
Fixing nuts	
Multifonction adjustment wrench	
User guide	
Valve extender	
Valve extender	
Rim tape	
Rim tape	

**COMPATIBILITY**

Freewheel: fixed cog only, flip-flop hub (one cog possible on each hub side)	
Freewheel: fixed cog only, flip-flop hub (one cog possible on each hub side). Cog thread: 1,37x24TPI. Lock ring thread: left thread M33x1	
Freewheel: fixed cog only, flip-flop hub (one cog possible on each hub side). Cog thread: 1,37x24TPI. Lock ring thread: left thread M33x1	
Freewheel: fixed cog only, flip-flop hub (one cog possible on each hub side). Cog thread: 1,37x24TPI. Lock ring thread: left thread M33x1	
Front axle: for fixing nuts only (included), M10x1 thread	
Front axle: for fixing nuts only (included), M10x1 thread	
Front axle: for fixing nuts only (included), M10x1 thread	
Rear axle: for fixing nuts only (included), M10x1 thread	
Rear axle: for fixing nuts only (included), M10x1 thread	
Rear axle: for fixing nuts only (included), M10x1 thread	
Rear axle: for fixing nuts only (included), M10x1 thread	
FTS-L Shimano / Sram freewheel body ([30871101] - Delivered on the wheel)	
FTS-L Campagnolo freewheel body ([30871201])	
Rear axle: 12mm thru axle, convertible to Quick Release with adapters (delivered with non-boost wheel)	