

# MAVIC CXR Ultimate 60 C

1  
2016  
FRONT

ASTM CATEGORY 1 : road only  
Recommended weight limit : 120kg  
Recommended tyre size: 23 mm  
Max. Pressure: 23mm 8.7 bars - 125 psi

## REFERENCES WHEELS

F33101 CXRUlt60C16Ft

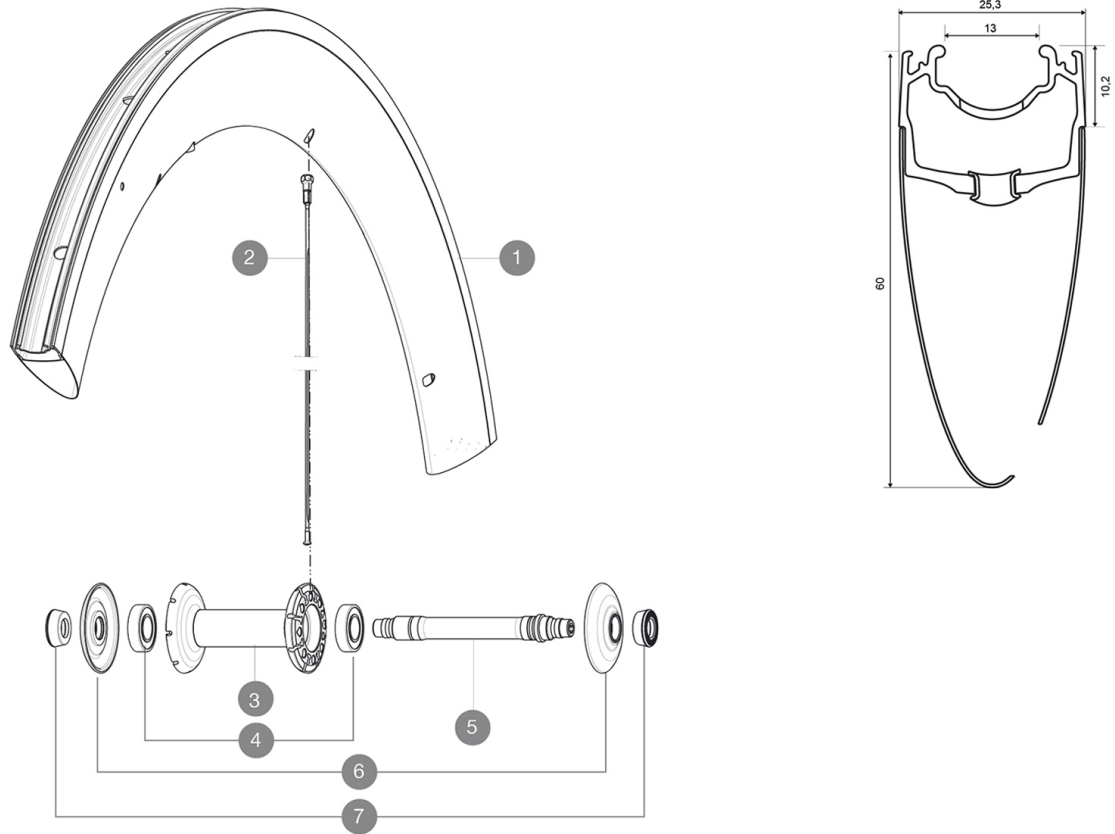

## RIMS



VALVE HOLE  $\bar{A}$  (MM): 6,5 :

1	V2403710	KIT FRONT RIM CXR60C 2016
---	----------	---------------------------

## SPOKES

2	32976801	KIT 10 AERO FT/NDS CXR 60 C BLK SPOKE 289mm
---	----------	---

## HUB SHELLS

3	N/A	HUB BODY
4	M40078	FRONT HUB BEARINGS 6901 x 2
5	30870001	FRONT AXLE ROAD RIM BRAKING QRM +
6	32985701	HUB CAP & ADJUSTING NUT CXR 80

## ADAPTERS

7	35117301	FT/RR FORK REST R-SYS/CC ULTIMATE > 2013/KSY PRO CARB T
---	----------	---

**MAVIC** *CXR Ultimate 60 C***DELIVERED WITH**

BR601 quick releases	
Rim tape	
BR601 quick releases	
CXR specific Exalith brake pads	
Valve extender	
Multifonction adjustment wrench	
CXR specific Exalith brake pads	
User guide	
Valve extender	
Rim tape	
Multifonction adjustment wrench	
User guide	

**Specifications****RIMS**

- **Material** : Mactal and 12K carbon fiber
- **Height** : 60 mm, Width 27 mm with CX01 groves
- **Joint** : SUP
- **Drilling** : traditional
- **Brake track** : Exalith 2
- **Material** : Mactal and 12K carbon fiber
- **Weight reduction** : ISM
- **Valve hole diameter** : 6.5 mm
- **Tyre** : clincher
- **ETRTO size** : 622x13C
- **Recommended tyre size** : 23 mm
- **Height** : 60 mm, Width 27 mm with CX01 groves
- **Joint** : SUP
- **Drilling** : traditional
- **Brake track** : Exalith 2
- **Weight reduction** : ISM
- **Valve hole diameter** : 6.5 mm
- **Tyre** : clincher
- **ETRTO size** : 622x13C

**SPOKES**

- **Material** : steel
- **Shape** : straight pull, bladed, double butted
- **Nipples** : aluminum, ABS
- **Count** : front 16, rear 20

**WHEEL HUB**

- **Front and rear bodies** : carbon center tube and aluminum flanges
- **Front and rear bodies** : carbon center tube and aluminum flanges
- **Axle material** : aluminum
- Adjustable sealed cartridge bearings
- **Freewheel** : FTS-L steel
- **Axle material** : aluminum
- Adjustable sealed cartridge bearings
- **Freewheel** : FTS-L steel

**WHEEL WEIGHTS**

Wheel weight 820