

ASTM CATEGORY 1 : road only
Recommended weight limit : 120kg
Recommended tyre size: 23 mm
Max. Pressure: 23mm 8.7 bars - 125 psi

REFERENCES WHEELS

R57101 CXRUlt60C16Rr

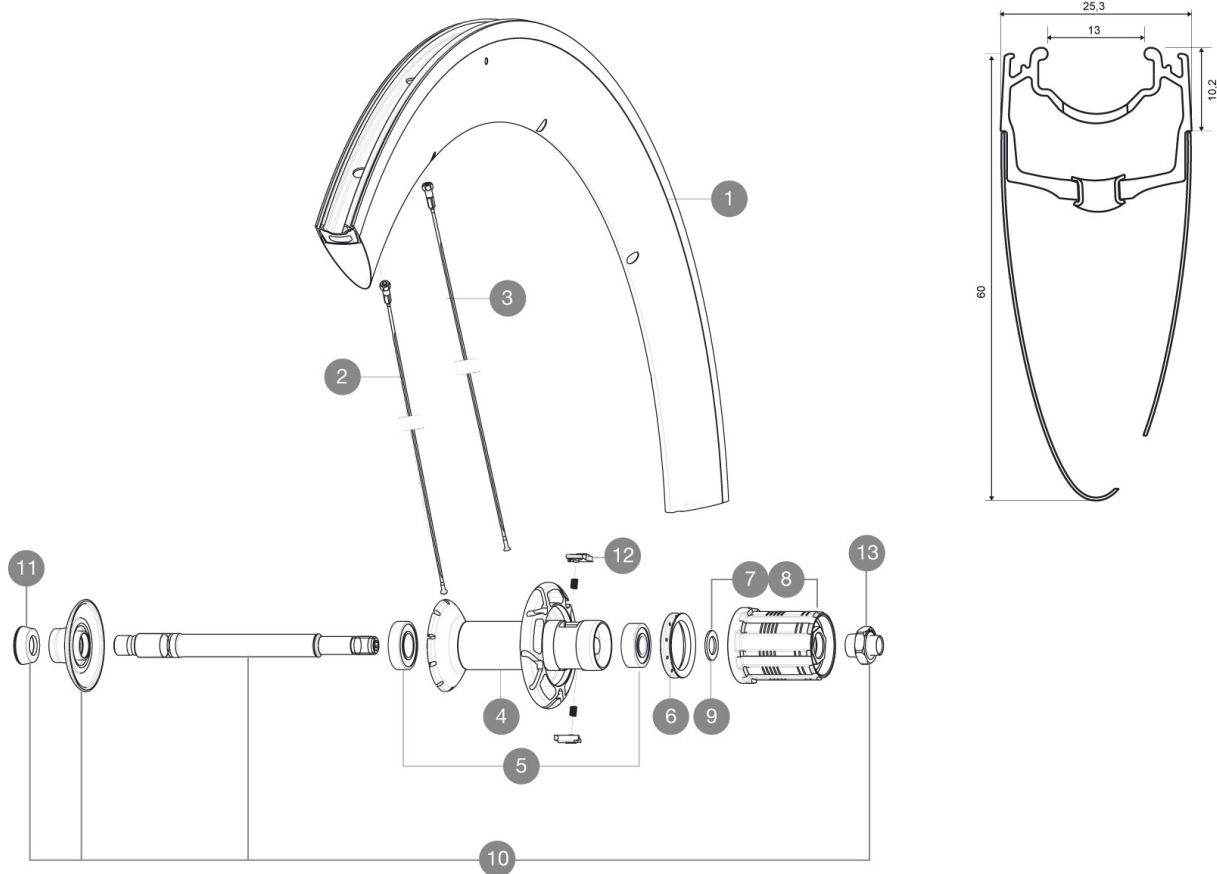

RIMS



VALVE HOLE \bar{A} (MM): 6,5 :

1 V2403813 KIT REAR RIM CXR60C 2016

ADAPTERS

11 35117301 FT/RR FORK REST R-SYS/CC ULTIMATE > 2013/KSY PRO CARB T

SPOKES

2 32976801 KIT 10 AERO FT/ND5 CXR 60 C BLK SPOKE 289mm
3 32976701 KIT 10 AERO DS CXR 60 C BLK SPK 287mm

HUB SHELLS

4	N/A	HUB BODY
5	33000001	REAR HUB B9+6901 BEARINGS 2013
6	99500001	FTSL/FTSX FREEHUB BODY SEAL
7	30871101	FTS-L ROAD FREEWHEEL BODY HG11 8/9 compatible
8	30871201	FTS-L ROAD FREEWHEEL BODY ED11 8/9 compatible
9	30872801	SET OF 3 INTERNAL SILVER SPACERS 9mm FTS-L
10	V2250301	KIT REAR AXLE AERO HUB CXR/CC40/CC SLS/CC SLE/COSMIC PRO CAR
12	M40578	FTSL PAWLS KIT (ROAD WHEELS)
13	V2373101	KIT NUT FOR ROAD ALLOY THROUGH AXLE 9mm

MAVIC CXR Ultimate 60 C

DELIVERED WITH

BR601 quick releases	
Rim tape	
BR601 quick releases	
CXR specific Exalith brake pads	
Valve extender	
Multifonction adjustment wrench	
CXR specific Exalith brake pads	
User guide	
Valve extender	
Rim tape	
Multifonction adjustment wrench	
User guide	

Specifications

RIMS

- **Material** : Mactal and 12K carbon fiber
- **Height** : 60 mm, Width 27 mm with CX01 groves
- **Joint** : SUP
- **Drilling** : traditional
- **Brake track** : Exalith 2
- **Material** : Mactal and 12K carbon fiber
- **Weight reduction** : ISM
- **Valve hole diameter** : 6.5 mm
- **Tyre** : clincher
- **ETRTO size** : 622x13C
- **Recommended tyre size** : 23 mm
- **Height** : 60 mm, Width 27 mm with CX01 groves
- **Joint** : SUP
- **Drilling** : traditional
- **Brake track** : Exalith 2
- **Weight reduction** : ISM
- **Valve hole diameter** : 6.5 mm
- **Tyre** : clincher
- **ETRTO size** : 622x13C

SPOKES

- **Material** : steel
- **Shape** : straight pull, bladed, double butted
- **Nipples** : aluminum, ABS
- **Count** : front 16, rear 20

WHEEL HUB

- **Front and rear bodies** : carbon center tube and aluminum flanges
- **Front and rear bodies** : carbon center tube and aluminum flanges
- **Axle material** : aluminum
- Adjustable sealed cartridge bearings
- **Freewheel** : FTS-L steel
- **Axle material** : aluminum
- Adjustable sealed cartridge bearings
- **Freewheel** : FTS-L steel

WHEEL WEIGHTS

Wheel weight 1005