

ASTM CATEGORY 3 : offroad with jumps less than 61cm

For a longer longevity of the wheel, Mavic recommends that the total weight supported by the wheels don't exceed 120kg, bike included

ETRTO recommended tyre sizes: 35mm to 69mm (1.4" to 2.7")

参照ホイール

F36701 XrideUST Quest29FtWTS

F71571

Xrd UST Quest29 Ft Boost WTS

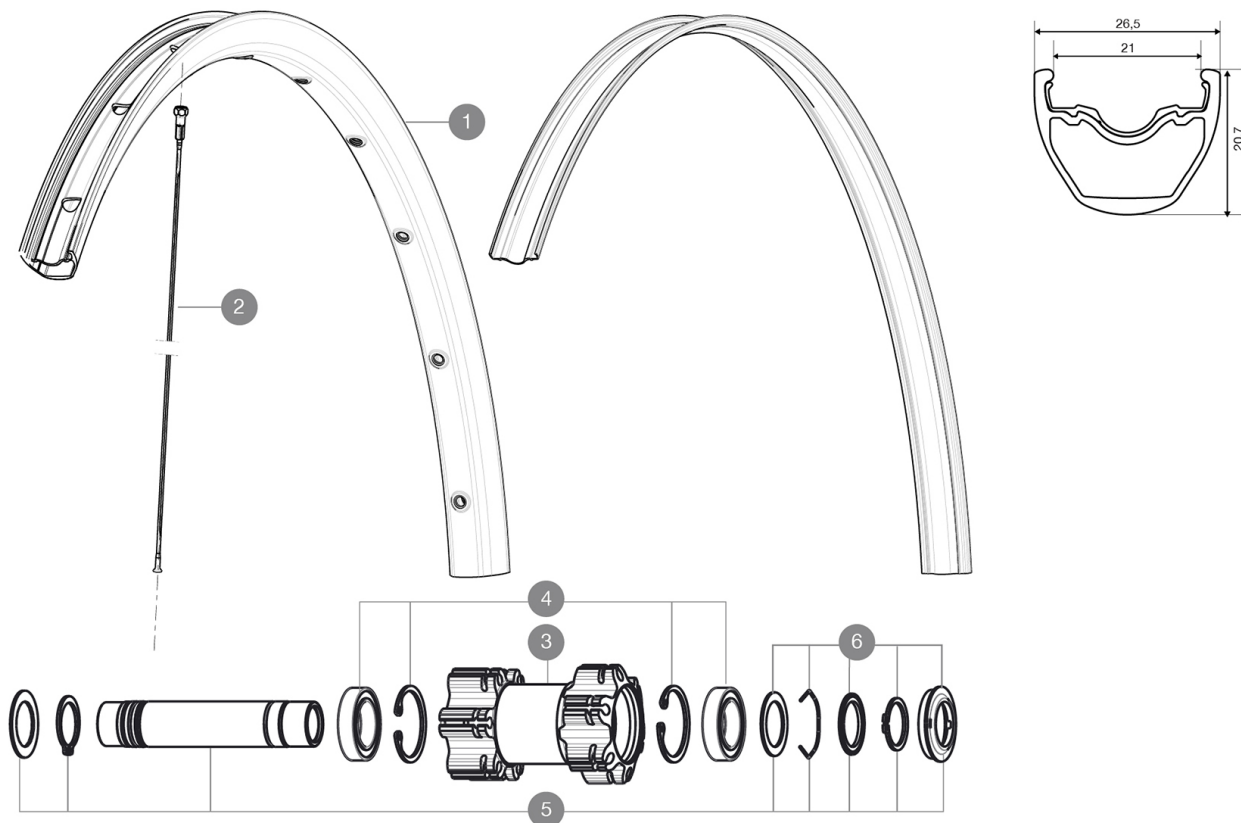

RIMS



バルブ穴径 (MM) : 6,5 :

1	V2314315	RIM CROSSRIDE TUBELESS 29
	V2190101	UST RIM STRIP 29x21c

SPOKES

2	36689601	"12 SPOKES DRIVE SIDE CROSSROC 29"" 293mm"
---	----------	--

HUB SHELLS

3	N/A	HUB BODY
4	99688501	BEARING KIT 9/15 D6T HUB
5	V2370101	KIT FRONT AXLE 15MM CROSSONE/-RIDE/-ROC - while stock last
5	V2371101	KIT FRONT QRM AXLE 100mm/BOOST 110mm
6	V2370301	FRONT AUTO ADJUST.PLAY KIT 15MM AXLE

MAVIC

Crossride Tubeless Quest 29

付属品

1 bottle of Mavic Sealant	
1 bottle of Mavic Sealant	
Tubeless rim tape	
UST valve and accessories	
Rear 12x142mm adapters	
User guide	
Rear 12x142mm adapters for ITS4 and TS2 (308 593 01 for ITS4, 329 650 01 for TS2) 1	
UST valve and accessories	
Tubeless rim tape	
User guide	

COMPATIBILITY

Freewheel: Shimano/Sram, convertible to XD with optional driver body	
Front axle: convertible from 15mm thru axle to Quick Release with optional adapters	
Rear axle: 12mm thru axle, convertible to Quick Release with optional adapters	

Specifications

リム

- Material : S6000 Aluminum
- Joint : sleeved
- Drilling : traditional with H2 reinforcement
- Valve hole diameter : 8,5 mm with pop off reducer
- Tyre : UST Tubeless and tubetype
- Material : S6000 Aluminum
- Internal width : 21 mm
- ETRTO size 26" : 559x21C
- ETRTO size 27.5" : 584x21C
- ETRTO size 29" : 622x21C
- ETRTO recommended tyre sizes : 35mm to 69mm (1.4" to 2.7")
- Joint : sleeved
- Drilling : traditional with H2 reinforcement
- Valve hole diameter : 8,5 mm with pop off reducer
- Tyre : UST Tubeless and tubetype
- Internal width : 21 mm
- ETRTO size 26" : 559x21C
- ETRTO size 27.5" : 584x21C
- ETRTO size 29" : 622x21C

スポーク

- Material : steel
- Shape : straight pull, bladed, double butted
- Nipples : brass, ABS
- Count : 24 front and rear
- Lacing : front and rear crossed 2
- Material : steel
- Shape : straight pull, bladed, double butted
- Nipples : steel, ABS
- Count : 24 front and rear
- Lacing : front and rear crossed 2

ホイールハブ

- Body : aluminum
- Axle material : aluminum
- Sealed cartridge bearings
- Freewheel : TS-2 alloy
- Front and rear bodies : aluminum
- Shimano 11 speeds compatible
- Axle material : aluminum
- Sram XD Compatible (XX1-X01) with optional kit
- Sealed cartridge bearings
- Freewheel : TS-2 alloy

VERSIONS

- Color : Black only
- Disc standard : 6 Bolts only
- Hub width : Boost (front 110, rear 148) or Non-Boost (front 100, rear 135/142)

ホイールの重み

- ホイール重量 (クイックリリースおよびクリンチャーチューブラーを除く) (g) :
- Weight Front 26": 845
Weight Front 27.5": 875
Weight Front 29": 920