

ASTM CATEGORY 2 : road and offroad with jumps less than 15cm  
 Recommended weight limit : 120kg  
 Recommended tyre sizes: 23 to 32 mm  
 Max. Pressure: 23mm 8.7 bars - 125 psi, 25mm 7.7 bars - 110 psi

## REFERENCES WHEELS

F51401 Ksyrium Pro SL C Ft

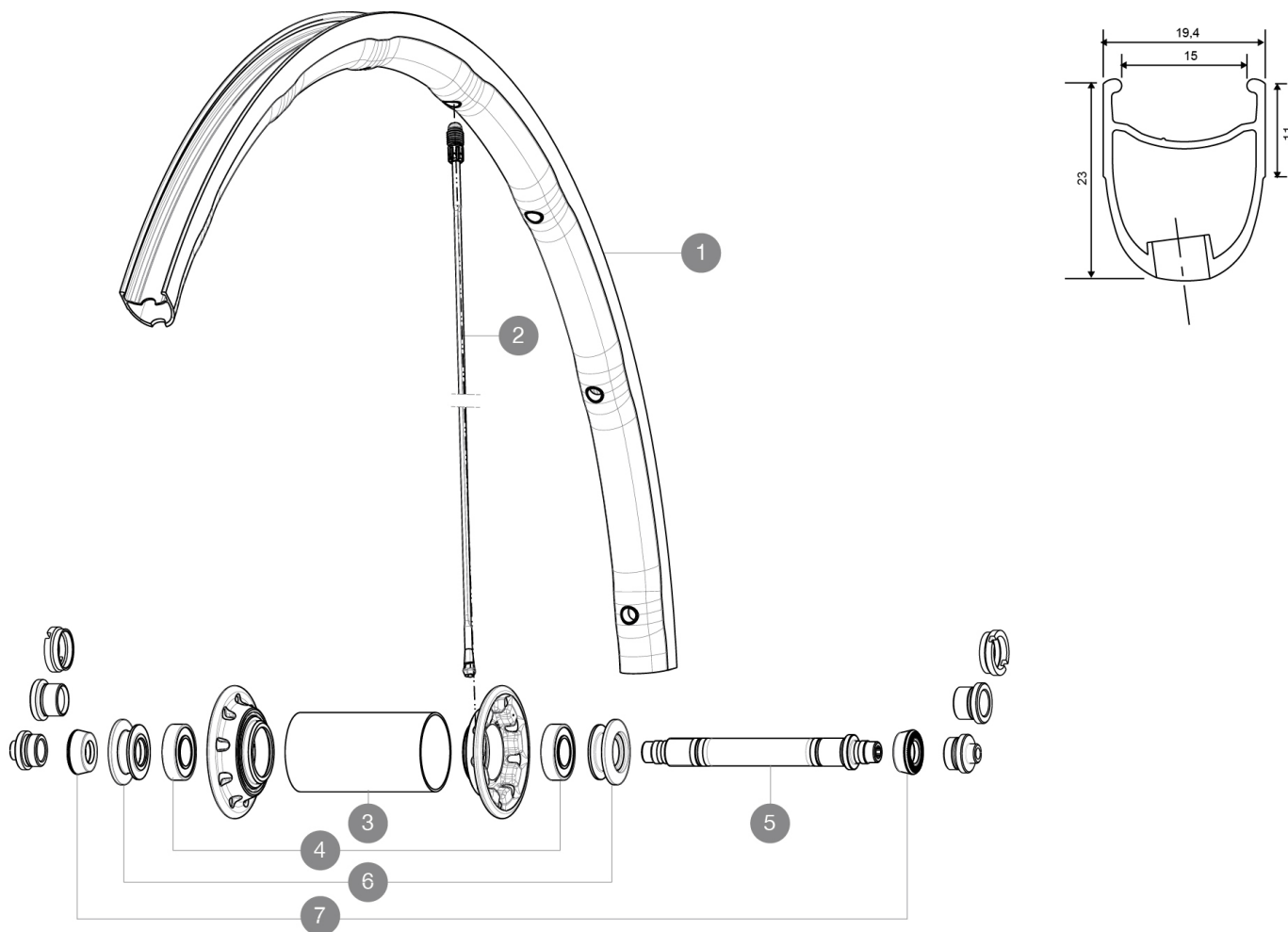

## RIMS



VALVE HOLE  $\bar{A}$  (MM): 6,5 :

1	V2401810	KIT FRONT RIM KSYRIUM PRO SL CLINCHER
---	----------	---------------------------------------

## SPOKES

2	V2276901	KIT 2 FT 282.5 & RR 273.5 STAMPED SPOKE KSYRIUM PRO - white
2	V2270601	KIT 9 FT KSY SLR/K125/PRO EXA SPK 282,5mm

## HUB SHELLS

3	N/A	HUB BODY
4	M40078	FRONT HUB BEARINGS 6901 x 2
5	32999801	FRONT AXLE KIT R-SYS/KSYRIUM SL/SLS 2013
6	M40759	ADJUSTING BEARING NUT + FRONT CAP

## ADAPTERS

7	35117301	FT/RR FORK REST R-SYS/CC ULTIMATE > 2013/KSY PRO CARB T
---	----------	---

**MAVIC** *Ksyrium Pro SL***DELIVERED WITH**

BR601 quick releases	
BR601 quick releases	
Multifonction adjustment wrench	
User guide	
Multifonction adjustment wrench	
User guide	

**COMPATIBILITY**

Freewheel: Shimano/Sram, convertible to Campagnolo with optional driver body	
Front axle: Quick Release only	
Rear axle: Quick Release only	

**Specifications****RIMS**

- **Material** : Mxstal
- **Height** : front 24mm, rear 26 asymmetrical
- **Joint** : SUP
- **Drilling** : Fore
- **Brake track** : UB Control
- **Weight reduction** : ISM 4D
- **Valve hole diameter** : 6.5 mm
- **Tyre** : clincher
- **Material** : Mxstal
- **Height** : front 24mm, rear 26 asymmetrical
- **ETRTO size** : 622x15C
- **Recommended tyre sizes** : 23 to 32 mm
- **Joint** : SUP
- **Drilling** : Fore
- **Brake track** : UB Control
- **Weight reduction** : ISM 4D
- **Valve hole diameter** : 6.5 mm
- **Tyre** : clincher
- **Internal width** : 15mm
- **ETRTO size** : 622x15C

**SPOKES**

- **Material** : Zicral
- **Shape** : straight pull, bladed, front double butted
- **Nipples** : Fore integrated aluminum
- **Material** : Zicral
- **Count** : front 18, rear 20
- **Lacing** : front radial, rear Isopulse
- **Shape** : straight pull, bladed, front double butted
- **Nipples** : Fore integrated aluminum
- **Count** : front 18, rear 20
- **Lacing** : front radial, rear Isopulse

**WHEEL HUB**

- **Front body** : carbon with aluminum flanges
- **Rear body** : aluminum
- **Rear body** : aluminum
- **Axle material** : aluminum
- **Front body** : carbon with aluminum flanges
- Adjustable sealed cartridge bearings
- **Freewheel** : FTS-L steel
- **Axle material** : aluminum
- Adjustable sealed cartridge bearings
- **Freewheel** : FTS-L steel

**VERSIONS**

- **Color** : Black only

**WHEEL WEIGHTS**

Wheel weight 600