

ASTM CATEGORY 2 : road and offroad with jumps less than 15cm
Recommended weight limit : 120kg
Recommended tyre sizes: 23 to 32 mm
Max. Pressure: 23mm 8.7 bars - 125 psi, 25mm 7.7 bars - 110 psi

REFERENCES WHEELS

R77101 Ksyrium Pro SL C Rr

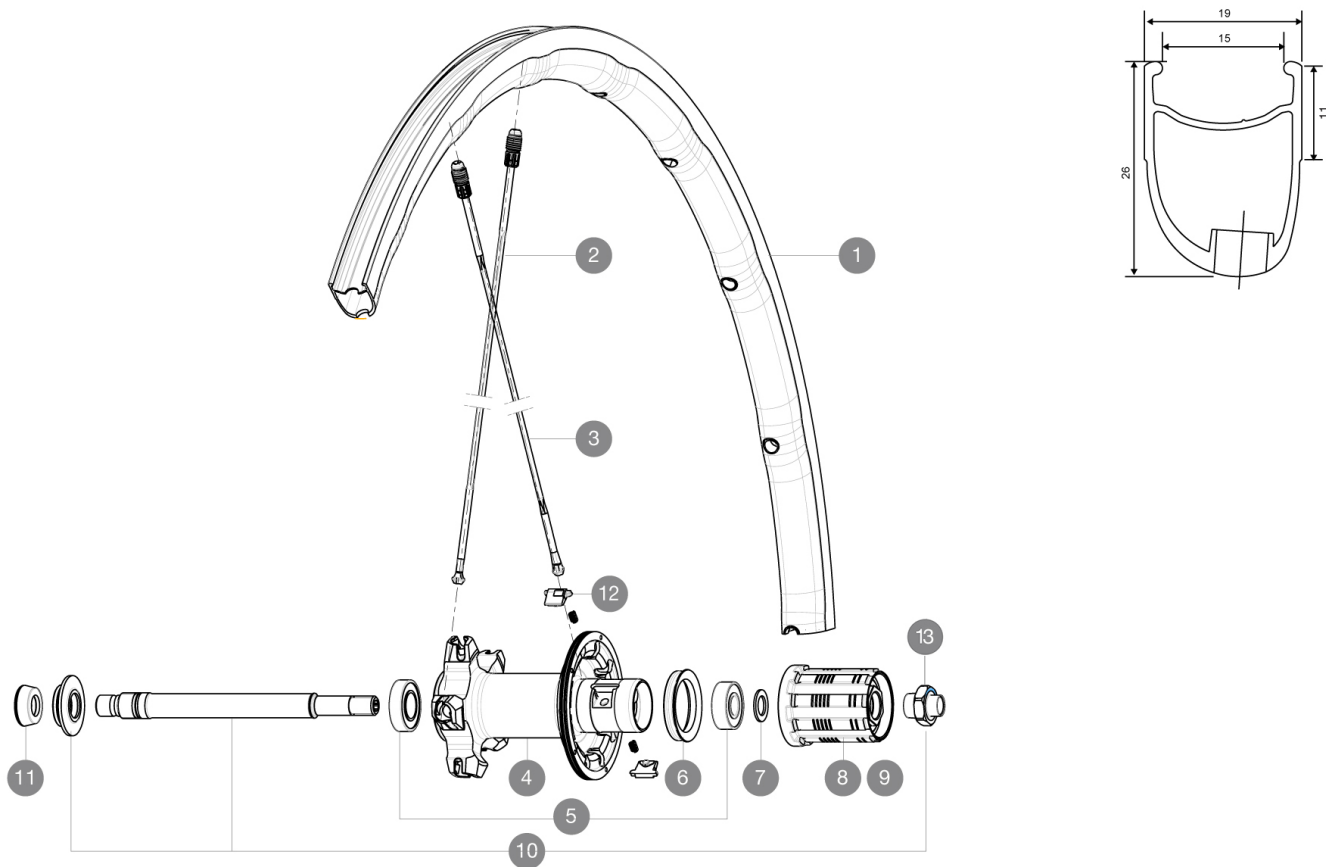

RIMS



VALVE HOLE \bar{A} (MM): 6,5 :

1	V2401913	KIT REAR RIM KSYRIUM PRO SL CLINCHER
---	----------	--------------------------------------

SPOKES

2	10844701	KIT 10 DS R-SYS SL/SLR TUB ALU BTD SPK 297,5mm
3	V2270501	KIT 12 DS KSY PRO/PRO DISC/SL C/PRO EXA SPK 273,5mm
3	V2276901	KIT 2 FT 282.5 & RR 273.5 STAMPED SPOKE KSYRIUM PRO - while

HUB SHELLS

4	N/A	HUB BODY
5	33000001	REAR HUB B9+6901 BEARINGS 2013
6	99500001	FTSL/FTSX FREEHUB BODY SEAL
7	30872801	SET OF 3 INTERNAL SILVER SPACERS 9mm FTS-L
8	30871101	FTS-L ROAD FREEWHEEL BODY HG11 8/9 compatible
9	30871201	FTS-L ROAD FREEWHEEL BODY ED11 8/9 compatible
10	V2250501	KIT REAR AXLE KSYRIUM SLE/SLS/ELITE/PRO EXALITH/ALLROAD ELIT
12	M40578	FTSL PAWLS KIT (ROAD WHEELS)
13	V2373101	KIT NUT FOR ROAD ALLOY THROUGH AXLE 9mm

ADAPTERS

11	35117301	FT/RR FORK REST R-SYS/CC ULTIMATE > 2013/KSY PRO CARB T
----	----------	---

MAVIC *Ksyrium Pro SL***DELIVERED WITH**

BR601 quick releases	
BR601 quick releases	
Multifonction adjustment wrench	
User guide	
Multifonction adjustment wrench	
User guide	

COMPATIBILITY

Freewheel: Shimano/Sram, convertible to Campagnolo with optional driver body	
Front axle: Quick Release only	
Rear axle: Quick Release only	

Specifications**RIMS**

- **Material** : Mxstal
- **Height** : front 24mm, rear 26 asymmetrical
- **Joint** : SUP
- **Drilling** : Fore
- **Brake track** : UB Control
- **Weight reduction** : ISM 4D
- **Valve hole diameter** : 6.5 mm
- **Material** : Mxstal
- **Tyre** : clincher
- **ETRTO size** : 622x15C
- **Height** : front 24mm, rear 26 asymmetrical
- **Recommended tyre sizes** : 23 to 32 mm
- **Joint** : SUP
- **Drilling** : Fore
- **Brake track** : UB Control
- **Weight reduction** : ISM 4D
- **Valve hole diameter** : 6.5 mm
- **Tyre** : clincher
- **Internal width** : 15mm
- **ETRTO size** : 622x15C

SPOKES

- **Material** : Zicral
- **Shape** : straight pull, bladed, front double butted
- **Nipples** : Fore integrated aluminum
- **Material** : Zicral
- **Count** : front 18, rear 20
- **Lacing** : front radial, rear Isopulse
- **Shape** : straight pull, bladed, front double butted
- **Nipples** : Fore integrated aluminum
- **Count** : front 18, rear 20
- **Lacing** : front radial, rear Isopulse

WHEEL HUB

- **Front body** : carbon with aluminum flanges
 - **Rear body** : aluminum
 - **Rear body** : aluminum
 - **Axle material** : aluminum
- Adjustable sealed cartridge bearings
- **Front body** : carbon with aluminum flanges
 - **Freewheel** : FTS-L steel
 - **Axle material** : aluminum
- Adjustable sealed cartridge bearings
- **Freewheel** : FTS-L steel

VERSIONS

- **Color** : Black only

WHEEL WEIGHTS

Wheel weight 795