

ASTM CATEGORY 3 : offroad with jumps less than 61cm
 For a longer longevity of the wheel, Mavic recommends that the total weight supported by the wheels doesn't exceed 150kg, bike included
 Maximum tyre pressure: 2.95bar/43PSI with a 52mm tyre - 1.55bar/22PSI with a 125mm tyre
 Recommended weight limit : 120kg
 Maximum tyre pressure: 3.2bar/46PSI with a 47mm tyre - 2.85bar/41PSI with a 64mm tyre
 ETRTO recommended tyre sizes: 25mm to 52mm (1" to 2.05")

REFERENCES WHEELS

F56901 CROSSRIDE RB 26 QR

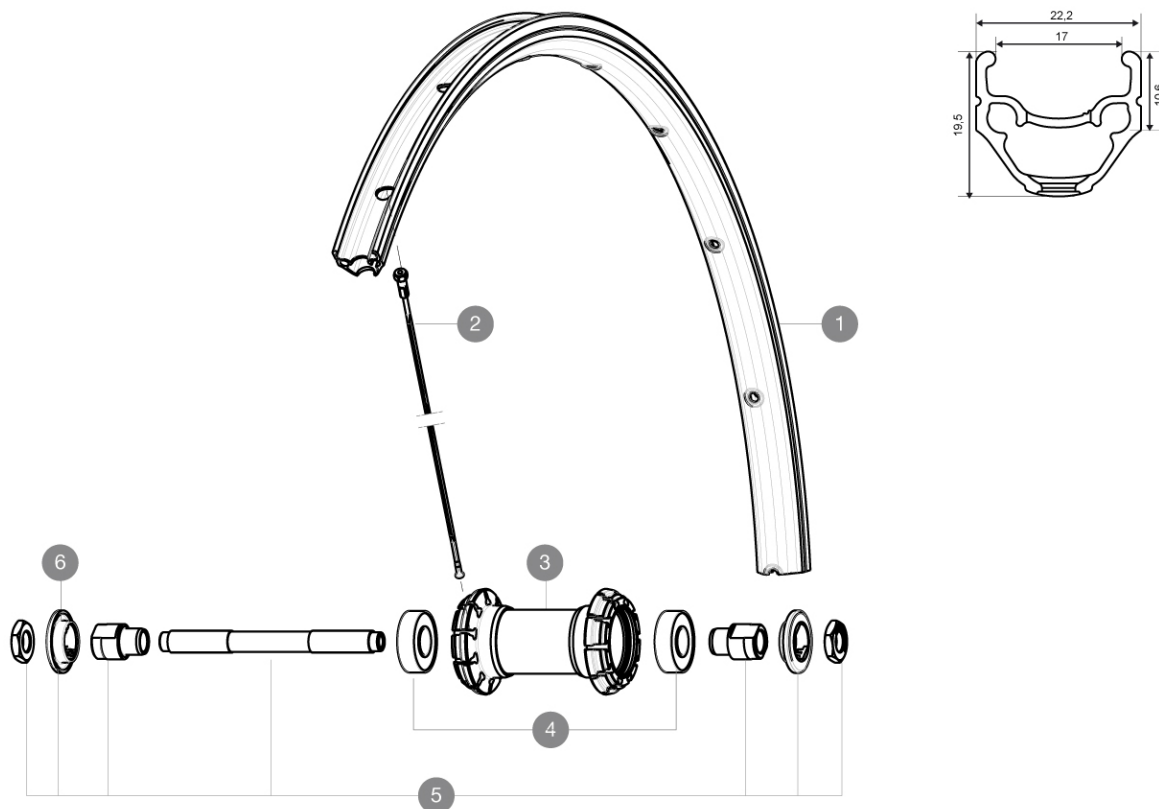

RIMS



VALVE HOLE (MM): 8,5 WITH POP OFF REDUCER :

1	12021815	KIT FRONT/REAR CROSSRIDE UB 2011 RIM
---	----------	--------------------------------------

SPOKES

2	99606901	KIT 10 FT/NDS CROSSRIDE UB 08 BLACK SPOKE
---	----------	---

HUB SHELLS

3	N/A	HUB BODY
4	M40318	KIT 2 HUB BEARINGS 6001
5	32347901	FRONT AXLE QRM UB
6	32348401	EXPANSIBLE BEARINGS SUPPORT

MAVIC CROSSRIDE UB 26

2016
FRONT

DELIVERED WITH

BR101 quick releases	
User guide	
Rim tape	
BR101 quick releases	
BR101 quick releases	
BR101 quick releases	
BR101 quick releases	
BR101 quick releases	
BR101 quick releases	
BR101 quick releases	
BR101 quick releases	
BR101 quick releases	
BR101 quick releases	
User guide	
Valve reducer	
Rear QR adapters (non-boost wheel)	
Rim tape	
Rim tape	
Rim tape	
Rim tape	

COMPATIBILITY

Freewheel: Shimano/Sram	
Freewheel: Shimano/Sram	
Freewheel: Shimano/Sram	
Freewheel: Shimano/Sram	
Front axle: Quick Release only	
Front axle: Quick Release only	
Front axle: Quick Release only	
Front axle: Quick Release only	
Front axle: Quick Release only	
Front axle: Quick Release only	
Front axle: Quick Release only	
Front axle: Quick Release only	
Front axle: Quick Release only	
Rear axle: Quick Release only	
Rear axle: Quick Release only	
Rear axle: Quick Release only	
Rear axle: Quick Release only	
Rear axle: Quick Release only	
Rear axle: 12mm thru axle, convertible to Quick Release with adapters (delivered with non-boost wheel)	