

ASTM CATEGORY 4 : offroad with jumps less than 122cm
Recommended weight limit : 120kg
Recommended tire sizes: 37 mm to 76 mm (1.5" to 3.0")

REFERENCES WHEELS

F70471	Dmx Pro 27,5 Ft Bst 15x110	F64801	Dmx Pro 27,5 Ft 15x100
--------	----------------------------	--------	------------------------

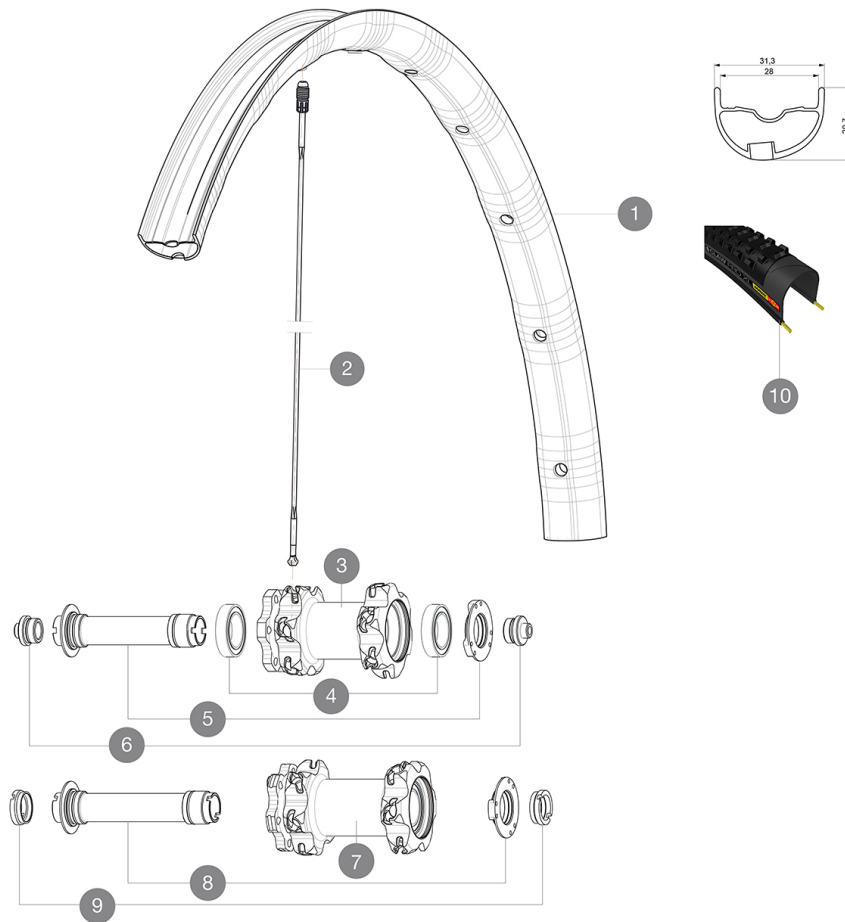

RIMS



VALVE HOLE \varnothing (MM): 6.5 :

1	V2319210	KIT FRONT RIM E-DEEMAX/DEEMAX PRO 27,5"
1	V2316410	KIT FRONT RIM DEEMAX PRO 27,5" 28mm TSS - while stock last

SPOKES

2	36674901	KIT 12 FT XMAX END/FT-NDS DEEMAX PRO 27,5" ALU SPK 275mm
---	----------	--

HUB SHELLS

3	N/A	HUB BODY
4	99688501	BEARING KIT 9/12/15 D6T HUB 20x32x7 6804
5	V2252301	KIT MY16 FRONT AXLE ROAD DISC 9/12/15 INT
7	N/A	HUB BODY
8	V2370701	KIT FRONT QRM+ AXLE BOOST INTL 110mm



TYRES

10	39243525	Claw Pro XL Tire 27.5
----	----------	-----------------------

ADAPTERS

6	B4104301	ADAPTER Ft 9mm QR QRM+
9	B4104401	ADAPTER Ft 15mm QRM+

DELIVERED WITH

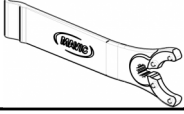
1 bottle of Mavic Sealant (355 466 01) 1	
Rear 12x142mm adapters for ITS4 and TS2 (308 593 01 for ITS4, 329 650 01 for TS2) 1	
UST valve and accessories (129 838 01)	
Multifunction adjustment wrench (325 423 01) 1	
User guide	

COMPATIBILITY

Freewheel: Shimano/Sram, convertible to XD with optional driver body	
Front axle: convertible from 15mm thru axle to Quick Release with optional adapters	
Rear axle: 12mm thru axle, convertible to Quick Release with optional adapters	

Specifications

RIMS

- **Drilling** : Fore
 - **Valve hole diameter** : 6.5 mm
 - **Tire** : UST Tubeless and tubetype
 - **Internal width** : 28 mm front and 25mm rear
 - **ETRTO size 27.5"** : 584x28ss front & 584x25ss rear
- Hookless profile

SPOKES

- **Material** : Zircal
- **Shape** : straight pull, bladed
- **Count** : 24 front and rear
- **Lacing** : front crossed 2, rear Isopulse

WHEEL HUB

- **Front and rear bodies** : aluminum
- Adjustable sealed cartridge bearings
- **Freewheel** : ITS-4 alloy

VERSIONS

- **Color** : Black only
- **Disc standard** : 6 Bolts only
- **Hub width** : Boost (front 110, rear 148) or Non-Boost (front 100, rear 135/142)

WHEEL WEIGHTS

Wheel weight 810