

ASTM CATEGORY 2 : road and offroad with jumps less than 15cm
 For a longer longevity of the wheel, Mavic recommends that the total weight supported by the wheels don't exceed 120kg, bike included
 Recommended tyre sizes: 25 to 32 mm
 Max. Pressure: 23mm 8.7 bars - 125 psi, 25/28mm 7.7 bars - 110 psi

REFERENCES WHEELS

F73911	Ksy18 D6BF12x100SR	F73921	Ksy18 DCLF12x100SR
--------	--------------------	--------	--------------------

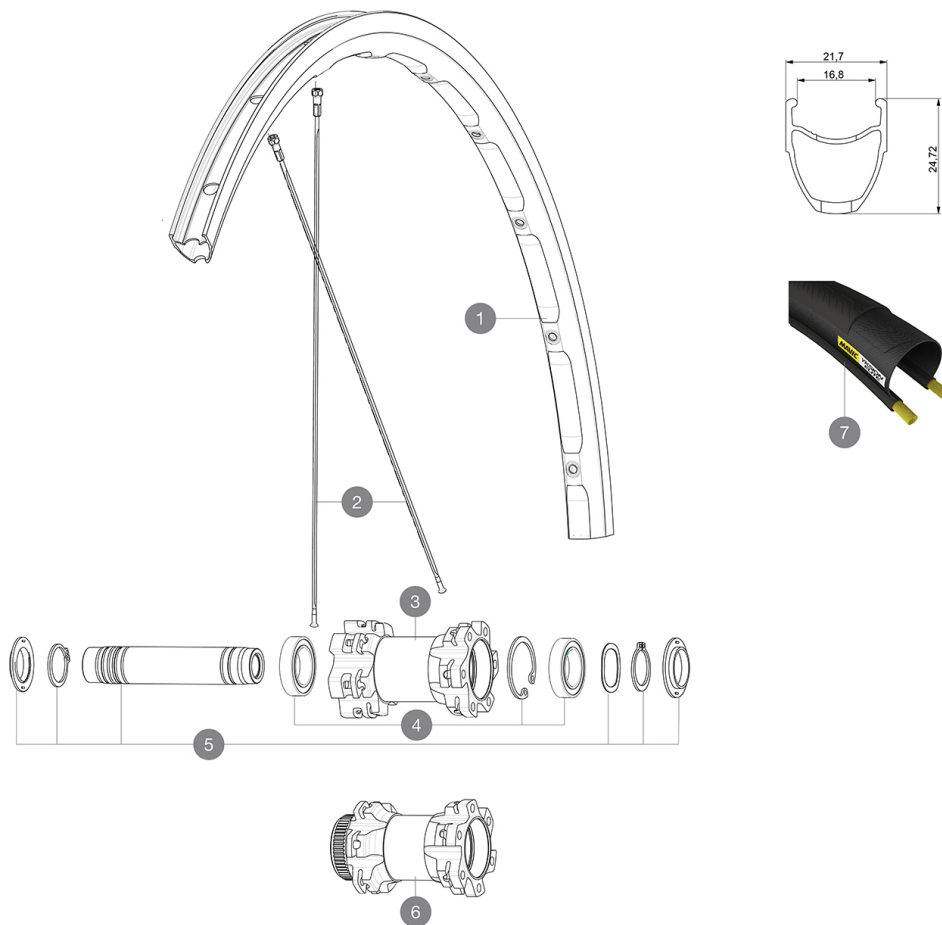

RIMS



&NBSP;:

1	V2409315	KIT FRONT/REAR RIM KSYRIUM DISC 17C
1	V2734315	KIT FRONT/REAR RIM KSYRIUM DISC 18 - while stock last

SPOKES

2	V3660401	KIT 12 FT/NDS KSYRIUM DISC FLAT SPOKE 291mm
---	----------	---

HUB SHELLS

3	N/A	HUB BODY
4	99688501	BEARING KIT 9/12/15 D6T HUB 20x32x7 6804
5	V2371801	KIT FRONT AXLE 12mm L1 + WAVED WASHER + CLIP
6	N/A	HUB BODY

OPTIONS

V2371901	KIT FRONT AXLE MTB L1 QRM AUTO 15x100mm
----------	---

TYRES

7	37805725	Yksion Elite
---	----------	--------------

ADAPTERS

V2390801	KIT 2 FORK RESTS FRONT AXLE MTB QRM AUTO
V2680301	"Kit Ft Road Adapter 12 >> 9mm"

MAVIC Ksyrium Disc

DELIVERED WITH

Rim tape	
User guide	

COMPATIBILITY

Freewheel: Shimano/Sram, convertible to Campagnolo and XD-R with optional driver bodies	
Front axle: 12mm thru axle. Optional: Easily convertible to quick release with adequate adapters, convertible to 15mm with complete axle replacement	
Rear axle: 12mm thru axle, convertible to Quick Release with optional adapters (not available in Germany)	

Specifications

RIMS

- **Material** : S6000 Aluminum
- **Height** : 24 mm
- **Joint** : SUP
- **Drilling** : traditional with H2 reinforcement

Disc brake specific profile

- **Weight reduction** : ISM
- **Valve hole diameter** : 6.5 mm
- **Tyre** : clincher
- **Internal width** : 17 mm
- **ETRTO size** : 622x17C

SPOKES

- **Material** : steel
- **Shape** : straight pull, bladed
- **Nipples** : steel, ABS
- **Count** : 24 front and rear
- **Lacing** : front and rear crossed 2

WHEEL HUB

- **Front and rear bodies** : aluminum
 - **Axle material** : aluminum
- Auto adjust sealed cartridge bearings (QRM Auto)
- **Freewheel** : Instant Drive 360 steel

VERSIONS

- **Color** : Black only
- **Disc standard** : 6 Bolts or Center Lock(R)

WHEEL WEIGHTS

845