

ASTM CATEGORY 2 : road and offroad with jumps less than 15cm
 ID360 Shimano HG9 alloy freewheel body (V3780101)
 For a longer longevity of the wheel, Mavic recommends that the total weight supported by the wheels don't exceed 120kg, bike included
 Maximum tyre pressure: 5.5bar/80PSI with a 28mm tyre - 3.25bar/47PSI with a 64mm tyre
 Recommended tyre sizes: 28 to 62 mm (1.1" to 2.5")
 Max. Pressure: see indication on wheel and tyre. If they differ, use the lower of the 2
 Max. Pressure: 30mm 5.8 bars - 85 PSI / 35mm 5.1 bars - 74 PSI / 40mm 4.5 bars - 65 PSI
 Rear axle: 12mm thru axle, convertible to Quick Release with optional adapters

REFERENCES WHEELS

F81241	ALLROAD INT 700 12X100	F81261	ALLROAD CL 700 12X100
--------	------------------------	--------	-----------------------

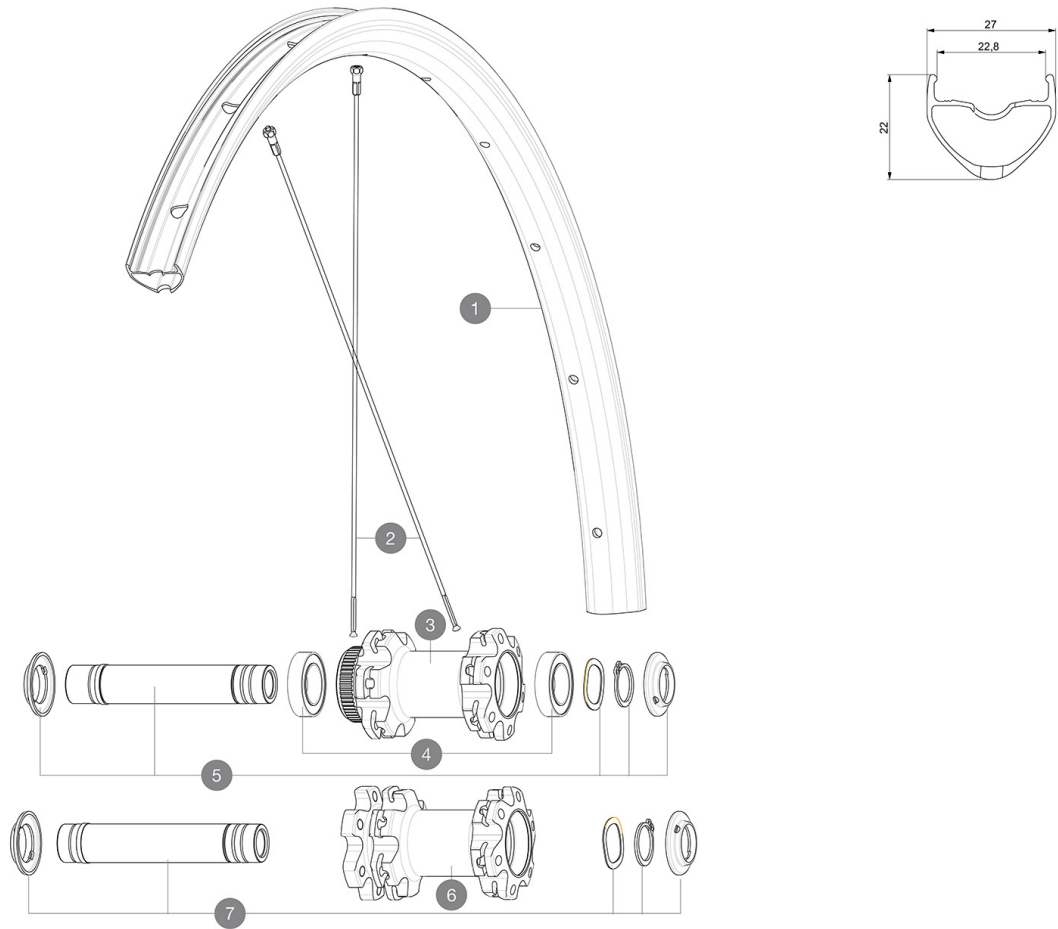

RIMS



&NBSP::

1	V2734915	KIT FRONT/REAR RIM ALLROAD UST Disc
	V2700101	UST Tape 28mm for 25 to 27mm wide rims

SPOKES

2	V3664601	KIT 12 FRT/NDS ALLROAD UST Disc ROUND SPOKE 296mm + nipple w
2	V2383001	KIT 12 FT/NDS CROSSRIDE FT SX 29" SPK 297mm

HUB SHELLS

3	N/A	HUB BODY
4	V2500901	KIT BEARINGS 18x30x7 + WAVED WASHER + CLIP
5	V2374001	KIT 12x100mm FRONT AXLE DCL QRM AUTO ALLROAD > 2019
7	V2374501	KIT 12mm FRT AXLE D6T QRM Auto Allroad 19

OPTIONS

V2373501	QRM Auto front axle 15mm for DCL Allroad wheels > 2019
V2372301	KIT 100mm AXLE QRM AUTO MTB > 2019

ADAPTERS

V2680301	"Kit Ft Road Adapter 12 >> 9mm"
V2372501	15mm MTB Axle Cap QRM Auto From 2019

DELIVERED WITH

User guide	
Front QR adapters (996 941 01 for MTB or B41 043 01 for road)	
Front QR adapters (996 941 01 for MTB or B41 043 01 for road)	
Front QR adapters (996 941 01 for MTB or B41 043 01 for road)	
Front QR adapters (996 941 01 for MTB or B41 043 01 for road)	
Front QR adapters (996 941 01 for MTB or B41 043 01 for road)	
Rear QR adapters for Instant Drive 360 (B49 894 01)	
Rear QR adapters for Instant Drive 360 (B49 894 01)	
Rear QR adapters for Instant Drive 360 (B49 894 01)	
Rear QR adapters for Instant Drive 360 (B49 894 01)	
Rear QR adapters for Instant Drive 360 (B49 894 01)	
Rear QR adapters for Instant Drive 360 (B49 894 01)	
UST valve and accessories (129 838 01)	
UST valve and accessories (129 838 01)	
UST valve and accessories (129 838 01)	
UST valve and accessories (129 838 01)	
UST valve and accessories (129 838 01)	
Tubeless rim tape	
Tubeless rim tape	

COMPATIBILITY

Freewheel: Shimano/Sram, convertible to Campagnolo and XD-R with optional driver bodies	
Freewheel: Shimano/Sram, convertible to Campagnolo and XD-R with optional driver bodies	
Freewheel: Shimano/Sram, convertible to Campagnolo and XD-R with optional driver bodies	
Freewheel: Shimano/Sram, convertible to Campagnolo and XD-R with optional driver bodies	
Front axle: 12mm thru axle, easily convertible to quick release with optional adapters. Convertible to 15mm with complete axle replacement	
Front axle: 12mm thru axle, easily convertible to quick release with included adapters. Convertible to 15mm with complete axle replacement	
Front axle: 12mm thru axle, easily convertible to quick release with included adapters. Convertible to 15mm with complete axle replacement	
Front axle: 12mm thru axle, easily convertible to quick release with included adapters. Convertible to 15mm with complete axle replacement	
Front axle: 12mm thru axle, easily convertible to quick release with included adapters. Convertible to 15mm with complete axle replacement	
Rear axle: 12mm thru axle, convertible to Quick Release with included adapters	
Freewheel body: convertible SRAM XD road (kit V2580101 sold separately)	
Rear axle: 12mm thru axle, convertible to Quick Release with included adapters	
Freewheel body: convertible SRAM XD road (kit V2580101 sold separately)	
Rear axle: 12mm thru axle, convertible to Quick Release with optional adapters	
Freewheel body: convertible SHIMANO HG light road (kit V3850101 sold separately)	
Freewheel body: convertible SHIMANO HG light road (kit V3850101 sold separately)	
Freewheel body: convertible SHIMANO MS (kit V3990101 sold separately)	
Freewheel body: convertible SHIMANO MS (kit V3990101 sold separately)	
Front axle: 12mm thru axle, easily convertible to quick release with included adapters. Convertible to 15mm with complete axle replacement	