

MAVIC **ALLROAD PRO CARBON SL DISC****REFERENCES WHEELS**

ASTM CATEGORY 2 : road and offroad with jumps less than 15cm

For a longer longevity of the wheel, Mavic recommends that the total weight supported by the wheels doesn't exceed 120kg, bike included

Maximum tyre pressure: 4.4bar/64PSI with a 28mm tyre - 2.6bar/38PSI with a 64mm tyre

Recommended tyre sizes: 28 to 64 mm (1.1" to 2.5")

Max. Pressure: see indication on wheel and tyre. If they differ, use the lowest of the 2

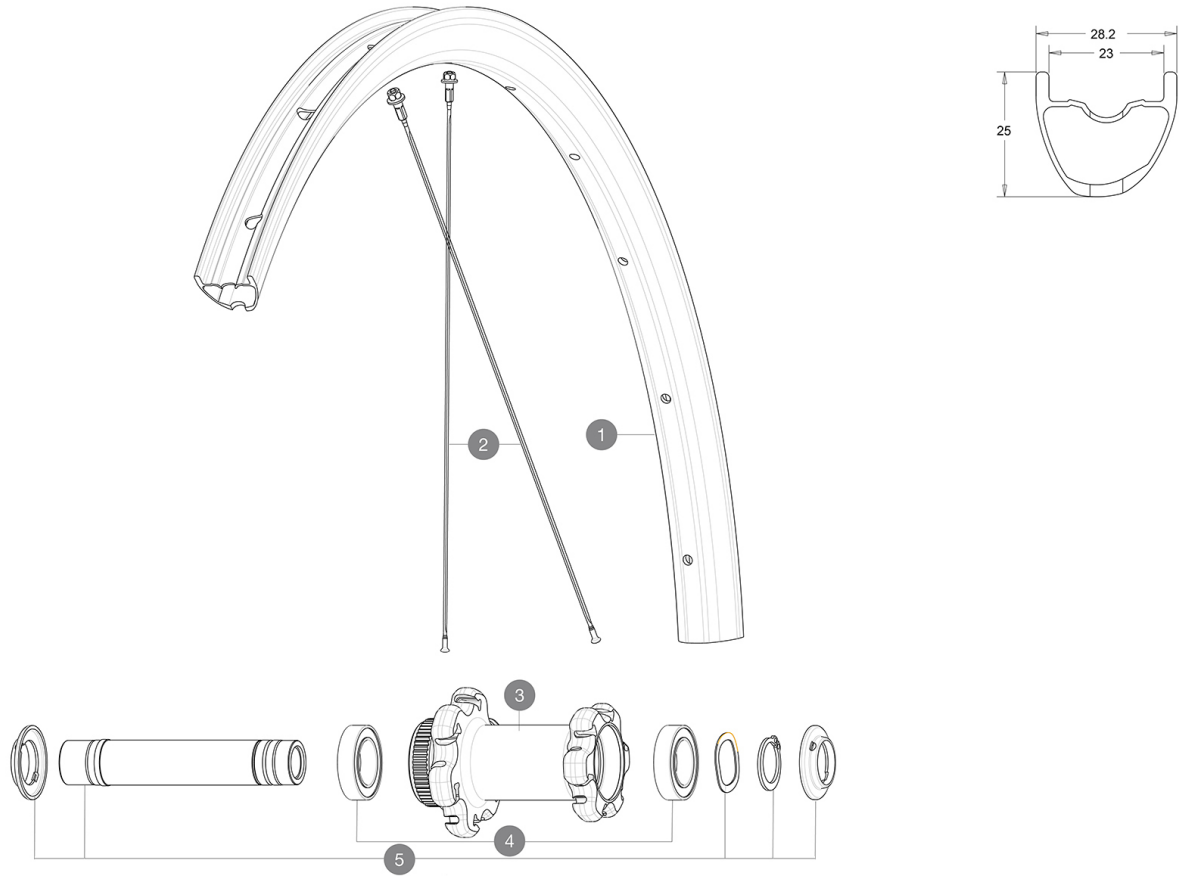
**RIMS**

&NBSP;:

1	V2738910	KIT FRONT RIM ALLROAD PRO CARBON SL -while stock last
1	V4092410	Kit Front rim EBM Allroad Pro Carbon SL while stock lasts
	V2620101	UST RIM TAPE 25mm (for 21-24mm wide rim)

SPOKES

2	V3668301	Kit 2 FRONT/NDS Allroad Pro Carbon SL stamped spoke 291 + al
2	V3821801	KIT 12 FRT/REAR CROSSMAX PRO CARBON 29" EXTRA FLAT SPOKE 29

HUB SHELLS

3	N/A	HUB BODY
4	V2500901	KIT BEARINGS 18x30x7 + WAVED WASHER + CLIP
5	V2374001	KIT 12x100mm FRONT AXLE DCL QRM AUTO ALLROAD > 2019
5	V2374101	KIT QRM AUTO FRONT L3 AXLE 100x12mm DCL - while stock last

OPTIONS

V2372301	KIT 100mm AXLE QRM AUTO MTB > 2019
V2373501	QRM Auto front axle 15mm for DCL Allroad wheels > 2019

ADAPTERS

V2680301	"Kit Ft Road Adapter 12 >> 9mm"
V2372501	15mm MTB Axle Cap QRM Auto From 2019

DELIVERED WITH

Mavic tyre sealant (rear wheel) (355 466 01)	
Tyre sealant syringe	
Front QR adapters (996 941 01 for MTB or B41 043 01 for road)	
Rear QR adapters for Instant Drive 360 (B49 894 01)	
UST valve and accessories (129 838 01)	
UST valve and accessories (129 838 01)	
Pre-installed tubeless rim tape	
User guide	
User guide	

COMPATIBILITY

Freewheel: Shimano/Sram, convertible to Campagnolo and XD-R with optional driver bodies	
Freewheel: Shimano/Sram, convertible to Campagnolo and XD-R with optional driver bodies	
Front axle: 12mm thru axle, easily convertible to quick release with included adapters. Convertible to 15mm with complete axle replacement	
Front axle: 12mm thru axle, easily convertible to quick release with included adapters. Convertible to 15mm with complete axle replacement	
Rear axle: 12mm thru axle, convertible to Quick Release with optional adapters and axle replacement	
Rear axle: 12mm thru axle, convertible to Quick Release with included adapters	

Specifications

RIMS

- **Material** : 100% Unidirectional carbon fiber
- **Material** : 100% Unidirectional carbon fiber
- **Height** : 25mm
- **Height** : 25mm
- **Drilling** : traditional
- **Drilling** : traditional

Disc brake specific profile

Disc brake specific profile

- **Valve hole diameter** : 6.5 mm
- **Valve hole diameter** : 6.5 mm
- **Tire** : UST Tubeless and tubetype
- **Tire** : UST Tubeless and tubetype
- **Internal width** : 23 mm
- **Internal width** : 23 mm
- **ETRTO size** : 622x23TSS Road
- **ETRTO size** : 622x23TSS Road

Hookless profile

Hookless profile

Use with Mavic Tubeless Tape

Use with Mavic Tubeless Tape

UST Tubeless Ready

UST Tubeless Ready

SPOKES

- **Material** : steel
 - **Material** : steel
 - **Shape** : straight pull, flat, double butted
 - **Shape** : straight pull, flat, double butted
 - **Nipples** : aluminum, ABS
 - **Nipples** : aluminum, ABS
 - **Count** : 24 front and rear
 - **Count** : 24 front and rear
 - **Lacing** : front crossed 2, rear Isopulse
 - **Lacing** : front crossed 2, rear Isopulse
- Isopulse
Isopulse

WHEEL HUB

- **Front and rear bodies** : aluminum
 - **Axle material** : aluminum
- Instant Drive 360
QRM Auto
- **Front** : Quick release, 12x100 and 15x100 through axle compatible
 - **Front and rear bodies** : aluminum
 - **Axle material** : aluminum
 - **Rear** : Quick Release, 12x142 and 12x135 compatible
- Hub available for Center Lock brake rotors only
- **Front** : Quick release, 12x100 and 15x100 through axle compatible
 - **Rear** : Quick Release, 12x142 and 12x135 compatible
- Instant Drive 360
QRM Auto

VERSIONS

- **Color** : Black only
- **Color** : Black only
- **Disc standard** : Center Lock (R) only
- **Disc standard** : Center Lock (R) only
- **Freewheel** : Shimano/Sram

WHEEL WEIGHTS

670