



ALLROAD S DISC

参照ホイール

F90221 ALLROAD S CL 700 12X100

ASTM A2106 2 : 15 + 15
120
28 64 mm (1.1" 2.5")
Maximum tyre pressure: 4.6bar/67PSI with a 28mm tyre - 32.7bar/39PSI with a 64mm tyre

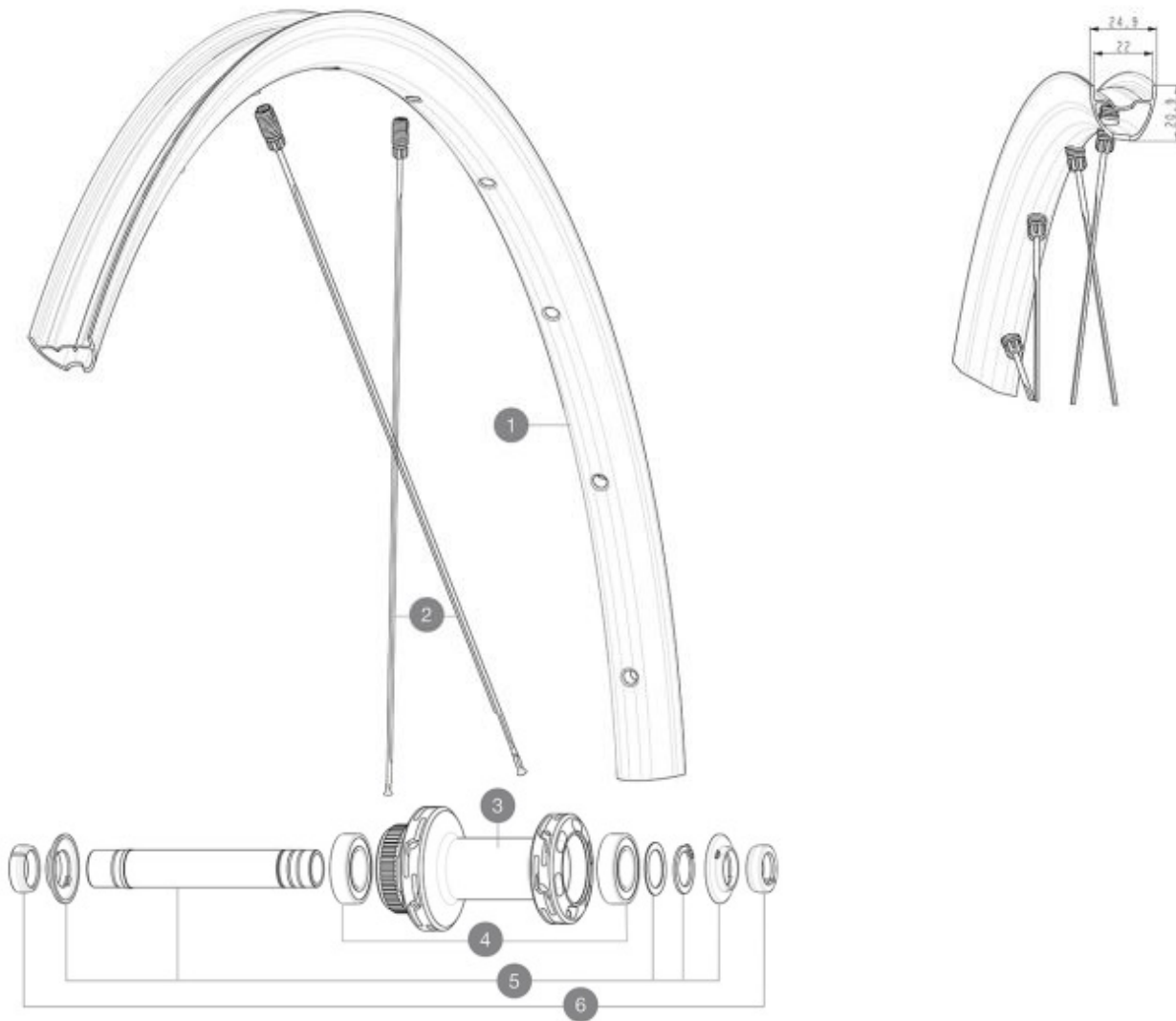

RIMS



&NBSP;:

1	V00097531	Kit Front/Rear rim Allroad S 23
1	V4092115	Kit Front/Rear rim Allroad S while stock lasts

SPOKES

2	V4162601	Kit 12 Front/Rear Allroad S flat spoke 298 M7/7
---	----------	---

HUB SHELLS

3	N/A	HUB BODY
4	V2500901	KIT BEARINGS 18x30x7 + WAVED WASHER + CLIP
5	V2374001	KIT 12x100mm FRONT AXLE DCL QRM AUTO ALLROAD > 2019

OPTIONS

6	V2372501	15mm MTB Axle Cap QRM Auto From 2019
	V2680301	"Kit Ft Road Adapter 12 >> 9mm"
	V2373501	QRM Auto front axle 15mm for DCL Allroad wheels > 2019

