

# MAVIC ALLROAD S DISC

2021  
REAR

ASTM CATEGORY 2 : road and offroad with jumps less than 15cm

For a longer longevity of the wheel, Mavic recommends that the total weight supported by the wheels doesn't exceed 120kg, bike included

Maximum tyre pressure: 4.6bar/67PSI with a 28mm tyre - 32.7bar/39PSI with a 64mm tyre

Recommended tyre sizes: 28 to 64 mm (1.1" to 2.5")

Max. Pressure: see indication on wheel and tyre. If they differ, use the lowest of the 2

## REFERENCES WHEELS

R36751 ALLROAD S CL 700 12X142 M11 R38891 ALLROAD S CL 700 12X142 XDR

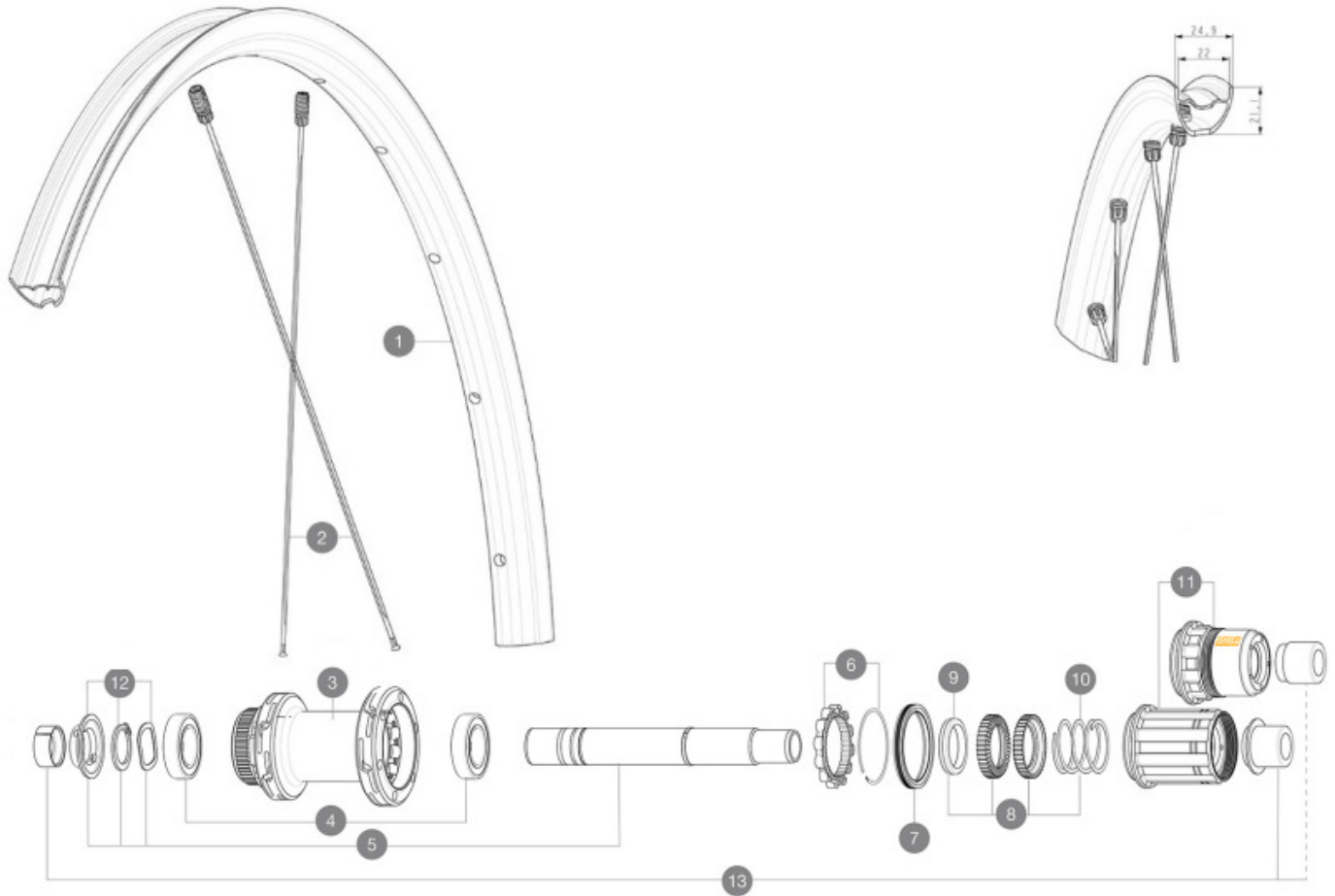

## RIMS



&NBSP;:

1	V4092115	Kit Front/Rear rim Allroad S while stock lasts
1	V00097531	Kit Front/Rear rim Allroad S 23

## SPOKES

2	V4162601	Kit 12 Front/Rear Allroad S flat spoke 298 M7/7
---	----------	---

## HUB SHELLS

3	N/A	HUB BODY
3	N/A	HUB BODY
4	M40076	HUB BEARINGS 17x30x7 6903 x 2
5	V2373401	KIT ID360 135/142 DCL L1 AXLE WITH CLIP
6	V2252701	KIT ID360 INSERT SHAPED EAR LOBE > 2017
7	V00063631	Kit ID360 seal version 2 (larger)
8	V2251701	KIT ID360 2 RATCHETS + SPRING + GREASE
9	V2500501	KIT ID360 3 PADS NOISE REDUCING
10	V2251801	KIT 3 ID360 ROAD SPRINGS
11	V3430101	HG11 Freewheel Body ID360
11	V2580101	FREEHUB BODY XD Road ID360
12	V2373001	KIT ADJUST. SYSTEM QRM AUTO ID360 for 17x30x7 bearing

## OPTIONS

V2510801	ID360 V2 RrAxleAdapt9x135
V2510901	ID360 EVO RrAxleAdpt12x135/150

## ADAPTERS

13	V3811001	KIT ROAD ID360 RR CL ENDCAP (12MM)
----	----------	------------------------------------

# MAVIC ALLROAD S DISC

## DELIVERED WITH

UST valve and accessories (129 838 01)	
UST valve and accessories (129 838 01)	
User guide	
User guide	

## COMPATIBILITY

Freewheel: Shimano/Sram, convertible to Campagnolo and XD-R with optional driver bodies	
Freewheel: Shimano/Sram, convertible to Campagnolo and XD-R with optional driver bodies	
Front axle: 12mm thru axle, easily convertible to quick release with optional adapters. Convertible to 15mm with complete axle replacement	
Front axle: 12mm thru axle, easily convertible to quick release with optional adapters. Convertible to 15mm with complete axle replacement	
Rear axle: 12mm thru axle, convertible to Quick Release with optional adapters	
Rear axle: 12mm thru axle, convertible to Quick Release with optional adapters	

## Specifications

### RIMS

- **Material** : Maxtal
  - **Material** : Maxtal
  - **Height** : 22 mm
  - **Height** : 22 mm
- SUP  
Disc brake specific profile  
Disc brake specific profile
- **Tire** : UST Tubeless and tubetype
  - **Tire** : UST Tubeless and tubetype
  - **Internal width** : 22 mm
  - **Internal width** : 22 mm
  - **ETRTO size** : 622x22TSS ROAD
  - **ETRTO size** : 622x22TSS ROAD
- Hookless profile  
Hookless profile  
Fore  
Fore  
UST  
UST  
SUP

### SPOKES

- **Material** : steel
- **Material** : steel
- **Shape** : straight pull, flat, double butted
- **Shape** : straight pull, flat, double butted
- **Nipples** : Fore integrated aluminum
- **Nipples** : Fore integrated aluminum
- **Count** : 24 front and rear
- **Count** : 24 front and rear
- **Lacing** : front and rear crossed 2, contactless
- **Lacing** : front and rear crossed 2, contactless

### WHEEL HUB

- Infinity Hub
- **Front and rear bodies** : aluminum
  - **Axle material** : aluminum
- Instant Drive 360  
QRM Auto
- **Front** : Quick release, 12x100 and 15x100 through axle compatible
  - **Front and rear bodies** : aluminum
  - **Rear** : Quick Release, 12x142 and 12x135 compatible
  - **Axle material** : aluminum
- Hub available for Center Lock brake rotors only
- **Front** : Quick release, 12x100 and 15x100 through axle compatible
  - **Rear** : Quick Release, 12x142 and 12x135 compatible
- Infinity Hub  
Instant Drive 360  
QRM Auto

### VERSIONS

- **Disc standard** : Center Lock (R) only
- **Disc standard** : Center Lock (R) only
- **Freewheel** : Shimano/Sram
- **Freewheel** : Shimano/Sram or XD-Road

### WHEEL WEIGHTS

935