

MAVIC ALLROAD SL DISC

ASTM CATEGORY 2 : road and offroad with jumps less than 15cm

For a longer longevity of the wheel, Mavic recommends that the total weight supported by the wheels doesn't exceed 120kg, bike included

Maximum tyre pressure: 4,6bar/67PSI with a 28mm tyre - 32,7bar/39PSI with a 64mm tyre

Recommended tyre sizes: 28 to 64 mm (1.1" to 2.5")

Max. Pressure: see indication on wheel and tyre. If they differ, use the lowest of the 2

REFERENCES WHEELS

F90331 ALL SL CL 700 12X100

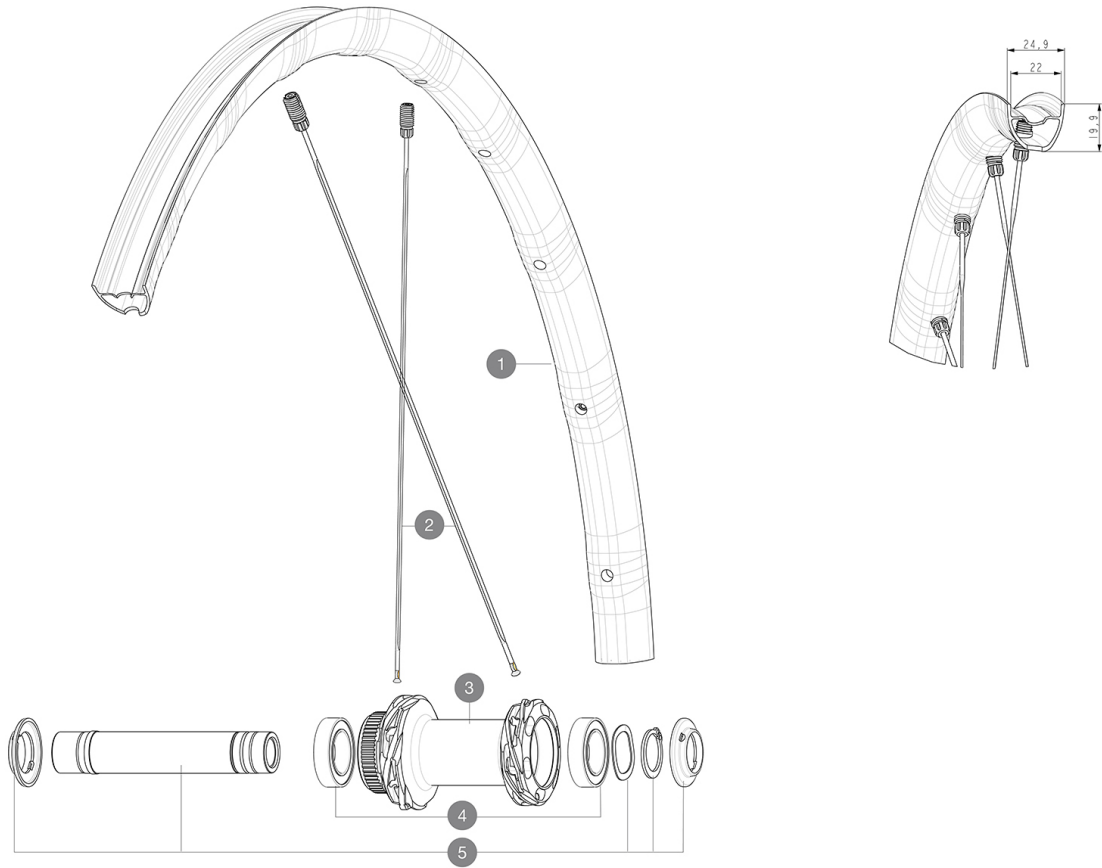
**RIMS**

&NBSP;:

1	V00097431	Kit Front/Rear rim Allroad SL 23
1	V4092015	Kit Front/Rear rim Allroad SL while stock lasts

SPOKES

2	V4162501	Kit 12 Front/Rear Allroad SL aero spoke 298 M7/7
---	----------	--

HUB SHELLS

3	N/A	HUB BODY
4	V2500901	KIT BEARINGS 18x30x7 + WAVED WASHER + CLIP
5	V2374001	KIT 12x100mm FRONT AXLE DCL QRM AUTO ALLROAD > 2019

OPTIONS

V2680301	"Kit Ft Road Adapter 12 >> 9mm"
V2373501	QRM Auto front axle 15mm for DCL Allroad wheels > 2019
V2372501	15mm MTB Axle Cap QRM Auto From 2019

DELIVERED WITH

UST valve and accessories (129 838 01)	
UST valve and accessories (129 838 01)	
User guide	
User guide	

COMPATIBILITY

Freewheel: Shimano/Sram, convertible to Campagnolo and XD-R with optional driver bodies	
Freewheel: Shimano/Sram, convertible to Campagnolo and XD-R with optional driver bodies	
Front axle: 12mm thru axle, easily convertible to quick release with optional adapters. Convertible to 15mm with complete axle replacement	
Front axle: 12mm thru axle, easily convertible to quick release with optional adapters. Convertible to 15mm with complete axle replacement	
Rear axle: 12mm thru axle, convertible to Quick Release with optional adapters	
Rear axle: 12mm thru axle, convertible to Quick Release with optional adapters	

Specifications

RIMS

- **Material** : Maxtal
 - **Material** : Maxtal
 - **Height** : 22 mm
 - **Height** : 22 mm
- SUP
Disc brake specific profile
Disc brake specific profile
- **Weight reduction** : ISM 4D
 - **Weight reduction** : ISM 4D
 - **Tire** : UST Tubeless and tubetype
 - **Tire** : UST Tubeless and tubetype
 - **Internal width** : 22 mm
 - **Internal width** : 22 mm
 - **ETRTO size** : 622x22TSS ROAD
 - **ETRTO size** : 622x22TSS ROAD
- Hookless profile
Hookless profile
Fore
Fore
UST
UST
SUP

SPOKES

- **Material** : steel
- **Material** : steel
- **Shape** : straight pull, elliptical aero, double butted (patented)
- **Shape** : straight pull, elliptical aero, double butted (patented)
- **Nipples** : Fore integrated aluminum
- **Nipples** : Fore integrated aluminum
- **Count** : 24 front and rear
- **Count** : 24 front and rear
- **Lacing** : front and rear crossed 2, contactless
- **Lacing** : front and rear crossed 2, contactless

WHEEL HUB

- Infinity Hub
- **Front and rear bodies** : aluminum
 - **Axle material** : aluminum
- Instant Drive 360
QRM Auto
- **Front** : Quick release, 12x100 and 15x100 through axle compatible
 - **Front and rear bodies** : aluminum
 - **Rear** : Quick Release, 12x142 and 12x135 compatible
 - **Axle material** : aluminum
- Hub available for Center Lock brake rotors only
- **Front** : Quick release, 12x100 and 15x100 through axle compatible
 - **Rear** : Quick Release, 12x142 and 12x135 compatible
- Infinity Hub
Instant Drive 360
QRM Auto

VERSIONS

- **Disc standard** : Center Lock (R) only
- **Disc standard** : Center Lock (R) only
- **Freewheel** : Shimano/Sram or XD-Road
- **Freewheel** : Shimano/Sram

WHEEL WEIGHTS

740