

ASTM CATEGORY 2 : road and offroad with jumps less than 15cm  
 For a longer longevity of the wheel, Mavic recommends that the total weight supported by the wheels doesn't exceed 120kg, bike included  
 Recommended tyre sizes: 28 to 64 mm (1.1" to 2.5")  
 Max. Pressure: see indication on wheel and tyre. If they differ, use the lowest of the 2  
 Maximum tyre pressure: 4.6bar/67PSI with a 28mm tyre - 32.7bar/39PSI with a 64mm tyre

## REFERENZEN RÄDER

R36881 ALL SL CL 700 12X142 M11      R39131 ALL SL CL 700 12X142 XDR

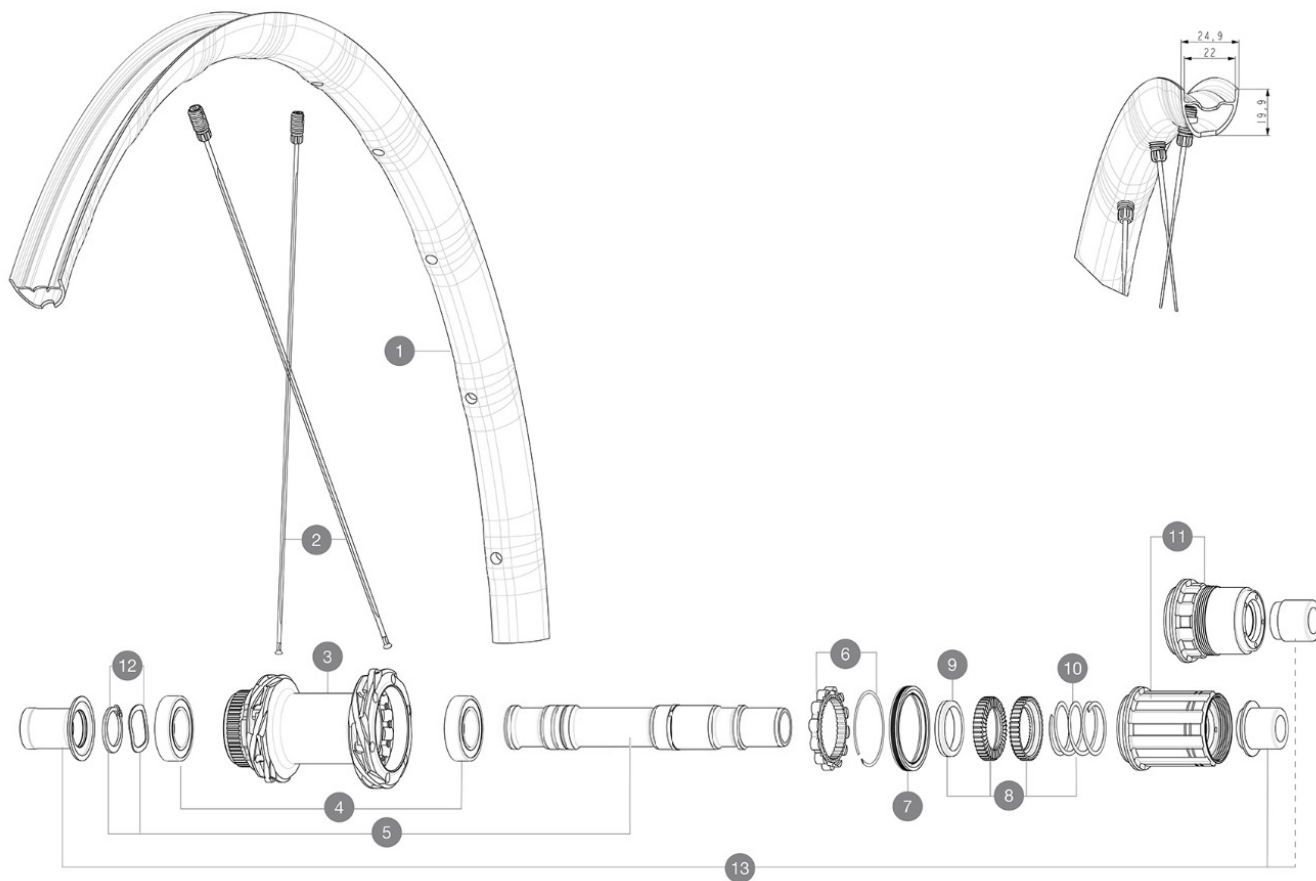

## RIMS



&NBSP;:

1	V00097431	Kit Front/Rear rim Allroad SL 23
1	V4092015	Kit Front/Rear rim Allroad SL while stock lasts

## SPOKES

2	V4162501	Kit 12 Front/Rear Allroad SL aero spoke 298 M7/7
---	----------	--

## HUB SHELLS

3	N/A	NABENKÖRPER
3	N/A	NABENKÖRPER
4	M40076	HUB BEARINGS 17x30x7 6903 x 2
5	V00046431	KIT AXE ID360 142LIGHT CL+CIR
6	V2252701	KIT ID360 INSERT SHAPED EAR LOBE > 2017
7	V00063631	Kit ID360 seal version 2 (larger)
8	V2251701	ID360 2 RATCHETS + SPRING + GREASE
9	V2500501	Kit 3 ID360 pad for noise reduction
10	V2251801	KIT 3 ID360 ROAD SPRINGS
11	V2580101	FREEHUB BODY XD Road ID360
11	V3430101	HG11 Freewheel Body ID360
12	V2373001	KIT ADJUST. SYSTEM QRM AUTO ID360 for 17x30x7 bearing

## OPTIONS

V2510801	ID360 EVO REAR AXLE ADAPTERS 9x135mm DCL & D6T
V2510901	ID360 EVO REAR AXLE ADAPTERS 12x135mm DCL & D6T
V2373401	KIT ID360 135/142 DCL L1 AXLE WITH CLIP
V2510701	ID360 EVO REAR AXLE ADAPTERS 12x142mm DCL & D6T

## ADAPTERS

13	V3811001	KIT ROAD ID360 RR CL ENDCAP (12MM)
----	----------	------------------------------------

# MAVIC ALLROAD SL DISC

## GELIEFERT MIT

UST valve and accessories (129 838 01)	
UST valve and accessories (129 838 01)	
UST valve and accessories (129 838 01)	
Multifunktions-Einstellschüssel (325 423 01)	
User guide	
User guide	
User guide	

## COMPATIBILITY

Freewheel: Shimano/Sram, convertible to Campagnolo and XD-R with optional driver bodies	
Freewheel: Shimano/Sram, convertible to Campagnolo and XD-R with optional driver bodies	
Freewheel: Shimano/Sram, convertible to Campagnolo and XD-R with optional driver bodies	
VR-Achse: 12x100 mm, umrÄ¼stbar auf Schnellspanner (mit beiliegenden Adaptern). UmrÄ¼stung auf 15x100 mm durch Austausch der kompletten Achse mÄ¼glich	
VR-Achse: 12x100 mm, umrÄ¼stbar auf Schnellspanner (mit beiliegenden Adaptern). UmrÄ¼stung auf 15x100 mm durch Austausch der kompletten Achse mÄ¼glich	
VR-Achse: 12-mm-Steckachse, mit optionalen Adaptern einfach auf Schnellspanner umrÄ¼stbar. UmrÄ¼stung auf 15-mm-Steckachse durch Austausch der komplet	
Rear axle: 12mm thru axle, convertible to Quick Release with optional adapters	
Rear axle: 12mm thru axle, convertible to Quick Release with optional adapters	
Rear axle: 12mm thru axle, convertible to Quick Release with optional adapters	

## Specifications

### FELGEN

- **Material** : Maxtal
  - **Height** : 22 mm
- Disc brake specific profile
- **Weight reduction** : ISM 4D
  - **Material** : Maxtal
  - **Material** : Maxtal
  - **Tire** : UST Tubeless and tubetype
  - **Height** : 22 mm
  - **Height** : 22 mm
  - **Internal width** : 22 mm
  - **ETRTO size** : 622x22TSS ROAD
- Hookless profile
- Disc brake specific profile
- Disc brake specific profile
- **Weight reduction** : ISM 4D
  - **Weight reduction** : ISM 4D
  - **Tire** : UST Tubeless and tubetype
  - **Tire** : UST Tubeless and tubetype
  - **Internal width** : 22 mm
  - **Internal width** : 22 mm
  - **ETRTO size** : 622x22TSS ROAD
  - **ETRTO size** : 622x22TSS ROAD

Hookless profile

Hookless profile

Fore

Fore

Fore

UST

UST

UST

SUP

SUP

SUP

SPEICHEN

### RADNABE

- **Front and rear bodies** : aluminum
  - **Front and rear bodies** : aluminum
  - **Front and rear bodies** : aluminum
  - **Axle material** : aluminum
  - **Axle material** : aluminum
  - **Axle material** : aluminum
- Infinity Hub
- **Front** : Quick release, 12x100 and 15x100 through axle compatible
  - **Front** : Quick release, 12x100 and 15x100 through axle compatible
  - **Front** : Quick release, 12x100 and 15x100 through axle compatible
  - **Rear** : Quick Release, 12x142 and 12x135 compatible
  - **Rear** : Quick Release, 12x142 and 12x135 compatible
  - **Rear** : Quick Release, 12x142 and 12x135 compatible
- Infinity Hub
- Infinity Hub
- Nabe nur fÄ¼r Center-LockÄ©-Bremsscheiben erhÄ¼tlich
- Instant Drive 360
- Instant Drive 360
- Instant Drive 360
- QRM Auto
- QRM Auto
- QRM Auto

### VERSIONS

- **Disc standard** : Center Lock (R) only
- **Disc standard** : Center Lock (R) only
- **Disc standard** : Center Lock (R) only
- **Freewheel** : Shimano/Sram or XD-Road

### RADGEWICHTE

850