

MAVIC CROSSMAX SL R 29

CATÉGORIE ASTM 3A : CROSS COUNTRY

Pour optimiser la longévité des roues, Mavic recommande que le poids maximal supporté par les roues ne dépasse pas 150 kg, poids du vélo inclus

Largeurs de pneu recommandées : 50 à 76 mm (2,0" à 3,0")

Maximum tyre pressure: 4.1bar/59PSI with a 28mm tyre - 2.45bar/36PSI with a 64mm tyre

Non-Boost : Adaptateurs axe arrière 12x135 ([V2510901])

Recommended tire sizes: 28 to 64 mm (1.1" to 2.5")

Boost : Adaptateurs Torque Cap ([V2374401])

RÉFÉRENCES ROUES

R41191	CROSSMAX SL R INT 29 BST	R41221	CROSSMAX SL R CL 29 BST MS
R41211	CROSSMAX SL R INT 29 BST XD		

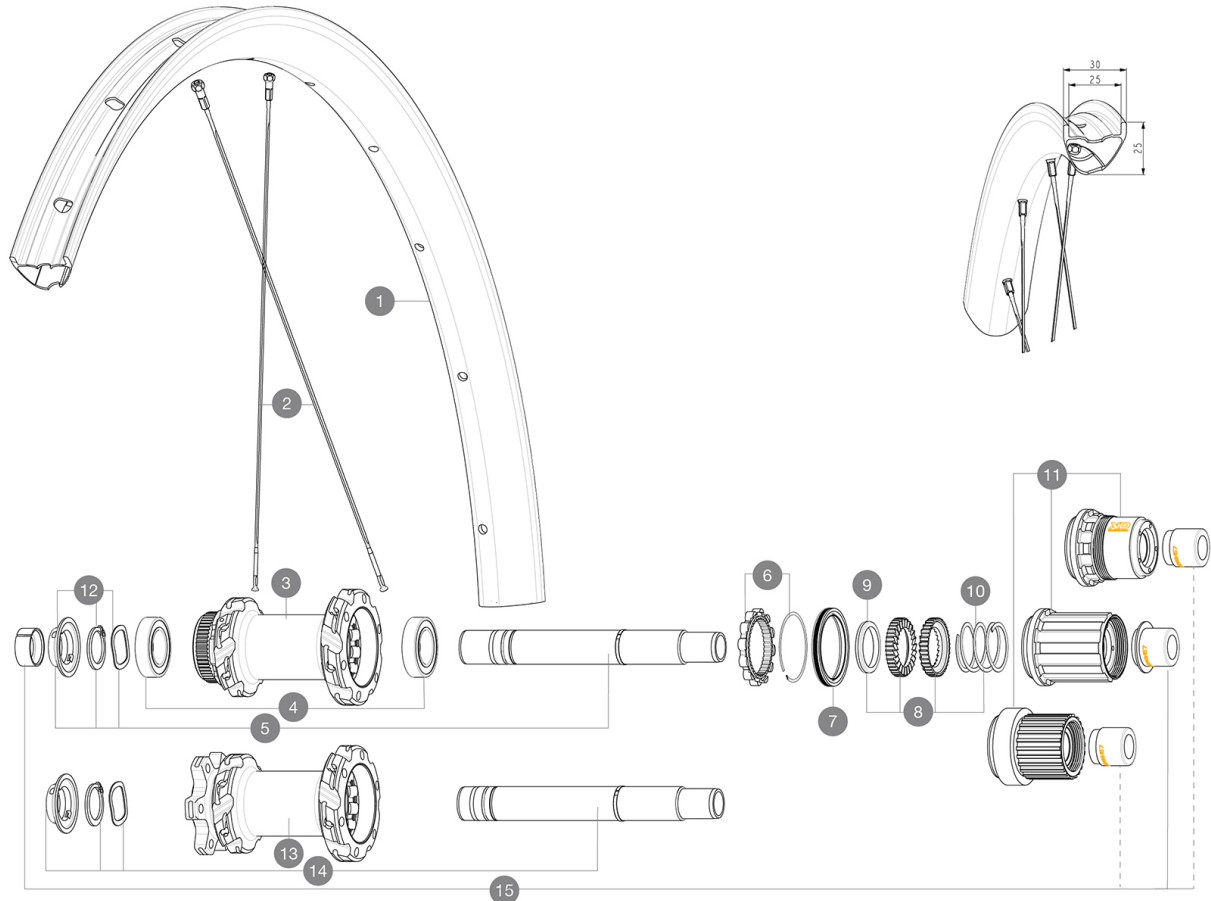

JANTES



 ::

1	V00004731	Kit Front/Rear rim Crossmax SLR 29" 22
	V2700101	UST Tape 28mm for 25 to 27mm wide rims

RAYONS

2	V00065231	Kit 12Fr/Rr MTBcarb29 ss spk293
2	V2389101	Kit 12Fr/Rr XmaxSL Ultimate spk293+np&w while stock lasts

MOYEURS

3	N/A	CORPS DE MOYEU
4	M40076	HUB BEARINGS 17x30x7 6903 x 2
5	V2375701	Kit ID360 148 DCL axle with circlip
6	V2252701	KIT ID360 INSERT SHAPED EAR LOBE > 2017
7	V00063631	Kit ID360 seal version 2 (larger)
8	V2375201	KIT ID360 24 TEETH 2 RATCHET + MTB SPRING + PAD (specific)
9	V2375401	KIT ID360 MTB 24T 3 NOISE REDUCING PADS
10	V2372901	KIT 3 ID360 MTB SPRINGS
11	V3990101	MicroSpline MTB Freewheel Body ID360
11	V3780101	HG9 Alloy MTB Freewheel Body ID360
11	V3740101	XD MTB Freewheel Body ID360
12	V2373001	KIT ADJUST. SYSTEM QRM AUTO ID360 for 17x30x7 bearing

13	N/A	CORPS DE MOYEU
14	V2372201	KIT ID360 148 D6T AXLE WITH CLIP

OPTIONS

8	V2372801	KIT ID360 2x40 TEETH RATCHETS + MTB SPRING + GREASE + PAD
---	----------	---

ADAPTATEURS

15	V2510701	ID360 EVO REAR AXLE ADAPTERS 12x142mm DCL & D6T
	V2510801	ID360 EVO REAR AXLE ADAPTERS 9x135mm DCL & D6T

MAVIC CROSSMAX SL R 29

LIVRE AVEC

Guide utilisateur	
2Â rayons de rechange par roue	
Valve et accessoires UST (129Â 838Â 01)	
Valve et accessoires UST (129Â 838Â 01)	
Valve et accessoires UST (129Â 838Â 01)	
Fond de jante tubeless prÂ©installÂ©	
Fond de jante tubeless prÂ©installÂ©	
Fond de jante tubeless prÂ©installÂ©	
ClÂ© multifonction (livrÂ©e avec la roue arriÂ©re) (325Â 423 01)	
ClÂ© multifonction (livrÂ©e avec la roue arriÂ©re) (325Â 423 01)	
Guide utilisateur	
Fond de jante tubeless prÂ©installÂ©	
Valve et accessoires UST (129Â 838Â 01)	
2Â rayons de rechange par roue	
Adaptateur arriÂ©re de 12 Â 9 mm pour blocage rapide (V2510801 vendu separement)	
2Â rayons de rechange par roue	
2Â rayons de rechange par roue	

COMPATIBILITE

Axe avantÂ : Axe traversant 15Â xÂ 110Â boost	
Axe arriÂ©reÂ : Axe traversant 12Â xÂ 148Â boost	
Axe avantÂ : Axe traversant 15Â xÂ 110Â boost	
Axe avantÂ : Axe traversant 15Â xÂ 110Â boost	
Corps de roue libre: convertible SHIMANO HG MTB acier (kit V3790101 vendu sÂ©parement)	
Corps de roue libre: convertible SHIMANO HG MTB acier (kit V3790101 vendu sÂ©parement)	
BoostÂ : adaptateur avantÂ 20 Â 15Â mm (12982801))	
Axe avantÂ : fixation par Â©crous uniquement (fournis), filetageÂ M9x1	
Adaptateurs axe arriÂ©re: 12x148 convertible en 9x141 (kit V2510801 vendu sÂ©parement)	
Adaptateurs axe arriÂ©re: 12x148 convertible en 9x141 (kit V2510801 vendu sÂ©parement)	
Axe arriÂ©reÂ : Axe traversant 12Â xÂ 148Â boost	
Axe avantÂ : Axe traversant 15Â xÂ 110Â boost	
Axes boostÂ : 15Â xÂ 110Â ; 12Â xÂ 148	
Axes boostÂ : 15Â xÂ 110Â ; 12Â xÂ 148	
Axe avantÂ : fixation par Â©crous uniquement (fournis), filetageÂ M9x1	
SystÂ©me de roue libre Instant DriveÂ 360 Le nouveau systÂ©me de roue libre Instant DriveÂ 360, plus lâ©ger, garantit un engagement extrÂ©mement rapide, avec un point tous les 9Â°. Un joint en caoutchouc surdimensionnÂ© sans contact rÂ©duit la friction Â son minimum, et un large choix d'adaptateurs le rend compatible avec un grand nombre de cadres et d'axes.	