

**ASTM CATEGORY 5 : GRAVITY RIDING FOCUSED ON THE DESCENT**

Maximum tyre pressure: 2.95bar/43PSI with a 52mm tyre - 1.55bar/22PSI with a 125mm tyre

Minimum tyre size: width 52mm - pressure max. 2.95Bar/43PSI

Recommended tire sizes: 60mm to 76mm (2.35" to 3.0")

For a longer longevity of the wheel, Mavic recommends that the total weight supported by the wheels doesn't exceed 180kg, E-bike included

**REFERENCES WHEELS**

F92741 E-DEEMAX 30 INT 29 BST

F92751 E-DEEMAX 30 CL 29 BST

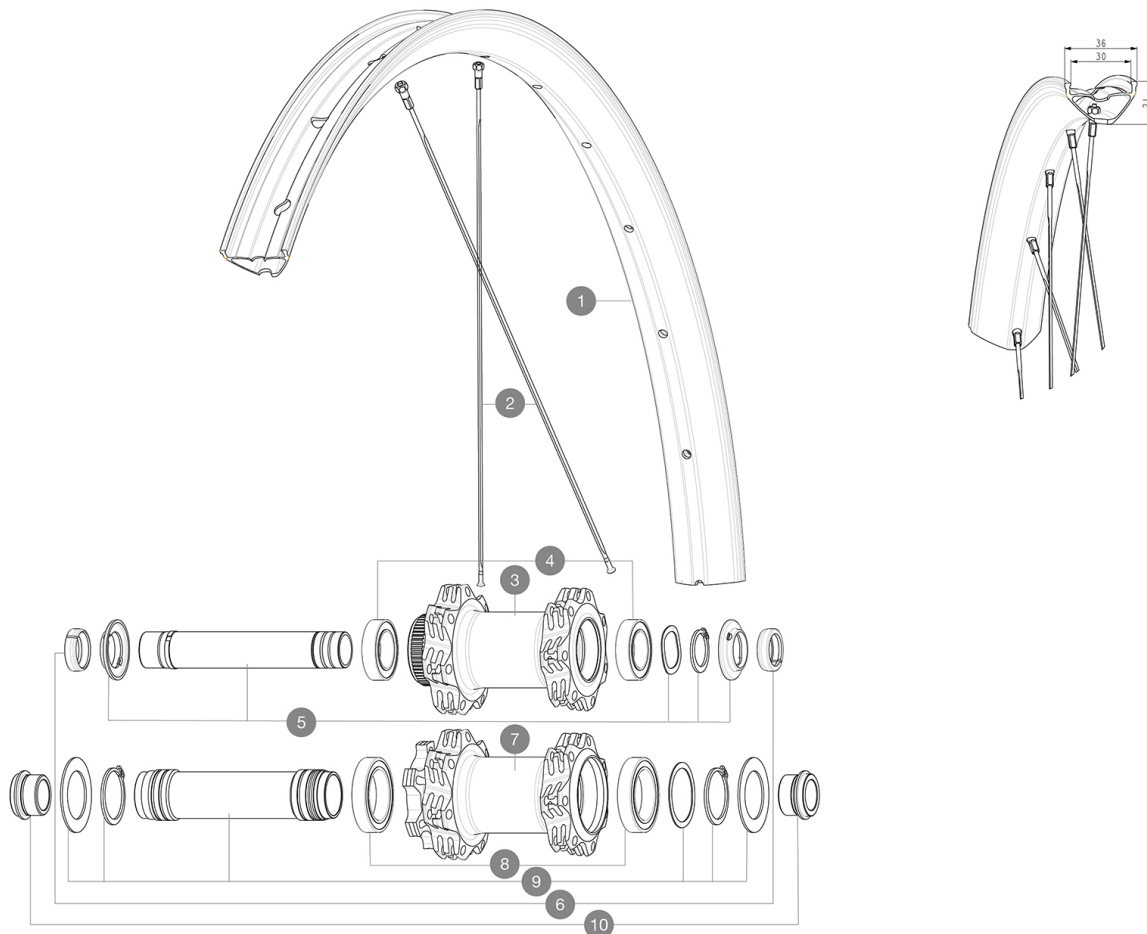

**RIMS**



&NBSP;:

|          |          |  |
|----------|----------|--|
| <b>1</b> | V3766915 | Kit Front/Rear rim eDeemax 30 29"      |
|          | V3750101 | 35mm UST Green Tape for 30mm wide rims |

**SPOKES**

|          |          |  |
|----------|----------|--|
| <b>2</b> | V2389501 | Kit 14 Front eDeemax 29" flat spoke 303 + nipple |
|----------|----------|--|

**HUB SHELLS**

|          |          |   |
|----------|----------|---|
| <b>3</b> | N/A      | HUB BODY                                    |
| <b>4</b> | V2500901 | KIT BEARINGS 18x30x7 + WAVED WASHER + CLIP  |
| <b>5</b> | V2375601 | Kit 110mm axle QRM auto MTB from 2019 DCL   |
| <b>7</b> | N/A      | HUB BODY                                    |
| <b>8</b> | M40179   | FRONT BEARING 25x37x7 20mm AXLE             |
| <b>9</b> | V2373701 | KIT 20x110mm BOOST AXLE QRM AUTO MTB > 2019 |

**OPTIONS**

|          |   |
|----------|---|
| V2650401 | TORQUECAP20*31 FT QRM AUTO MTB                        |
| V2374401 | TORQUE CAPS 15*31 Adapter MTB QRM Auto > 2019 Frt HUB |

**ADAPTERS**

|           |          |                                       |
|-----------|----------|---------------------------------------|
| <b>6</b>  | V2372501 | 15mm MTB Axle Cap QRM Auto From 2019  |
| <b>10</b> | 12982801 | ADAPTER Ft 20 to 15mm                 |
|           | V2680401 | 20x110 BOOST Front Adapter MTB wheels |
|           | 99694101 | ADAPTER Ft 15 to 9mm QR               |

# MAVIC E-DEEMAX 30 29

## DELIVERED WITH

|   |  |
|---|--|
| UST valve and accessories<br>(129 838 01)                       |  |
| UST valve and accessories<br>(129 838 01)                       |  |
| Pre-installed tubeless rim tape                                 |  |
| Pre-installed tubeless rim tape                                 |  |
| User guide  |  |
| Replacement spokes (2 with the front wheel and 4 with the rear) |  |
| Replacement spokes (2 with the front wheel and 4 with the rear) |  |

## COMPATIBILITY

|   |  |
|---|--|
| Freewheel body: convertible SHIMANO HG MTB steel (kit V3790101 sold separately) |  |
| Rear axle adapters: 12x148 convertible to 9x141 (kit V2510801 sold separately)  |  |
| Front axle: for fixing nuts only (included), M9x1 thread                        |  |

## Specifications

### RIMS

- **Material** : Mactal
  - **Height** : 22 mm
  - **Joint** : SUP welding technology
  - **Joint** : SUP welding technology
  - **Drilling** : traditional
- E-Bike specific rim profile
- **Tire** : UST Tubeless and tubetype
  - **Drilling** : traditional (front/rear 28 holes)
- Disc brake specific profile
- Asymmetrical rim design
- **ETRTO size 29"** : 622x30TC
- Pinch Flat Protection sidewall (minimizes the risk of tire cuts and punctures)
- Asymmetrical rim design
- **ETRTO size 29"** : 622x30TC
  - **Tire** : UST Tubeless and tubetype
  - **Tire** : clincher

### SPOKES

- **Material** : steel
- **Shape** : straight pull, flat
- **Count** : 28 front and rear
- **Lacing** : front radial, rear Isopulse
- **Lacing** : radial front and rear non-drive side, crossed 2 rear drive side
- **Lacing** : front and rear crossed 3

### WHEEL HUB

- **Body** : aluminum
- Instant Drive 360 freewheel technology  
QRM Auto bearing preload technology  
Hub available with 6-bolt or Center Lock® brake rotors
- **Axles** : Front 15X110 Boost ; Rear 12X148 Boost
  - **Disc standard** : 6 Bolts or Center Lock®
  - **Axle material** : aluminum
  - **Rear body** : aluminum
  - **Axles** : Front 15X110 (Boost) or 15x100 ; Rear 12X148 (Boost) or 12x142
  - **Freewheel** : Shimano HG MTB / Shimano MS / Sram XD MTB
  - **Freewheel** : FTS-L steel

### VERSIONS

- **Disc standard** : 6 Bolts or Center Lock®
- **Hub width** : Boost only (front 110, rear 148)
- **Freewheel** : SRAM XD, Shimano HG9, Shimano Micro-Spline

### WHEEL WEIGHTS

1035