

## ASTM CATEGORY 3 : CROSS COUNTRY

For a longer longevity of the wheel, Mavic recommends that the total weight supported by the wheels doesn't exceed 150kg, bike included

Maximum tyre pressure: 4.1bar/59PSI with a 28mm tyre - 2.45bar/36PSI with a 64mm tyre

Non-Boost : 12x135 rear axle adapters (V2510901)

Boost : Torque Caps for Center Lock hub (V2374401)

## REFERENCES WHEELS

F93071 XMAXSLULT 25 INT 29 BST

F93081 XMAXSLULT 25 CL 29 BST

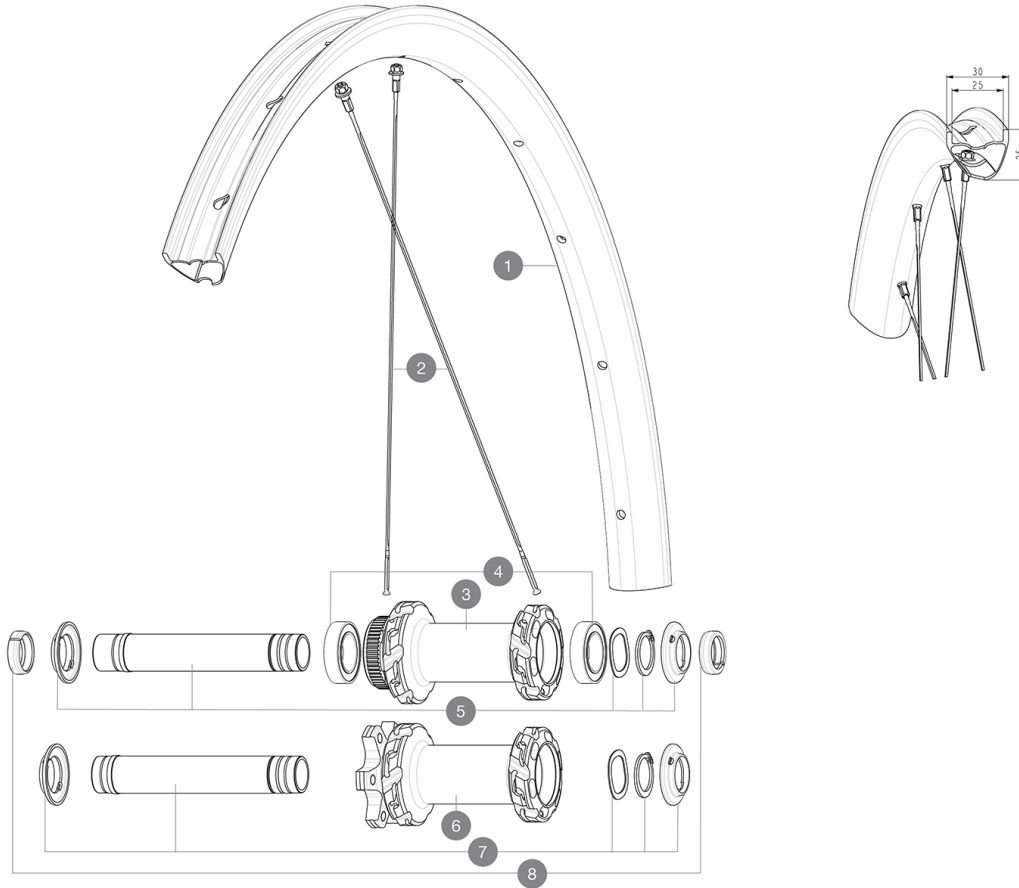

## RIMS



&amp;NBSP;:

1	V00004831	Kit Front/Rear rim Crossmax SL Ultimate 29" 22
	V2700101	UST Tape 28mm for 25 to 27mm wide rims

## SPOKES

2	V2389101	Kit 12Fr/Rr XmaxSL Ultimate spk293+np&w while stock lasts
2	V00065231	Kit12Fr/Rr MTBcarb29 ss spk293

## HUB SHELLS

3	N/A	HUB BODY
4	V2500901	KIT BEARINGS 18x30x7 + WAVED WASHER + CLIP
5	V2375601	Kit 110mm axle QRM auto MTB from 2019 DCL
6	N/A	HUB BODY
7	V2372401	KIT 110mm AXLE QRM AUTO MTB > 2019

## OPTIONS

V2374401	TORQUE CAPS 15*31 Adapter MTB QRM Auto > 2019 Frt HUB
----------	---

## ADAPTERS

8	V2372501	15mm MTB Axle Cap QRM Auto From 2019
	99694101	ADAPTER Ft 15 to 9mm QR

## DELIVERED WITH

User guide	
Wheelbag (V24 801 01)	
UST valve and accessories (129 838 01)	
UST valve and accessories (129 838 01)	
Pre-installed tubeless rim tape	
Multifunction adjustment wrench (delivered with rear wheel) (325 423 01)	
Wheelbag (V24 801 01)	
Wheelbag (V24 801 01)	
User guide	
Pre-installed tubeless rim tape	
UST valve and accessories (129 838 01)	
2 replacement spokes with each wheel	
12 to 9mm rear adapter for quick release (V2510801)	
2 replacement spokes with each wheel	
2 replacement spokes with each wheel	

## COMPATIBILITY

Freewheel body: convertible SHIMANO MS (kit V3990101 sold separately)	
Freewheel body: convertible SHIMANO MS (kit V3990101 sold separately)	
Front axle: 15x110 Boost thru axle	
Front axle: 15x110 Boost thru axle	
Freewheel body: convertible SHIMANO HG MTB steel (kit V3790101 sold separately)	
Freewheel body: convertible SHIMANO HG MTB steel (kit V3790101 sold separately)	
Boost 20 to 15mm front adapter ([12982801])	
Front axle: for fixing nuts only (included), M9x1 thread	
Rear axle adapters: 12x148 convertible to 9x141 (kit V2510801 sold separately)	
Rear axle adapters: 12x148 convertible to 9x141 (kit V2510801 sold separately)	
Rear axle: 12x148 Boost thru axle	
Front axle: 15x110 Boost thru axle	
Front axle: for fixing nuts only (included), M9x1 thread	

## Specifications

## RIMS

- **Material** : 100% carbon fiber with UD<sup>2</sup> external layer
- **Material** : 100% carbon fiber with UD<sup>2</sup> external layer
- **Material** : 100% carbon fiber with UD<sup>2</sup> external layer
- **Height** : 25 mm
- **Height** : 25 mm
- **Drilling** : traditional
- **Internal width** : 25 mm

## WHEEL HUB

- Infinity hubs
- **Body** : aluminum
  - **Body** : aluminum
- Instant Drive 360 freewheel technology  
QRM Auto bearing preload technology  
Hub available with 6-bolt or Center Lock<sup>®</sup> brake rotors
- **Axles** : Front 15X110 Boost ; Rear 12X148 Boost
  - **Body design** : INFINITY
  - **Body design** : INFINITY

## WHEEL WEIGHTS

615